

1164 (KH-32805)

PRO GYM

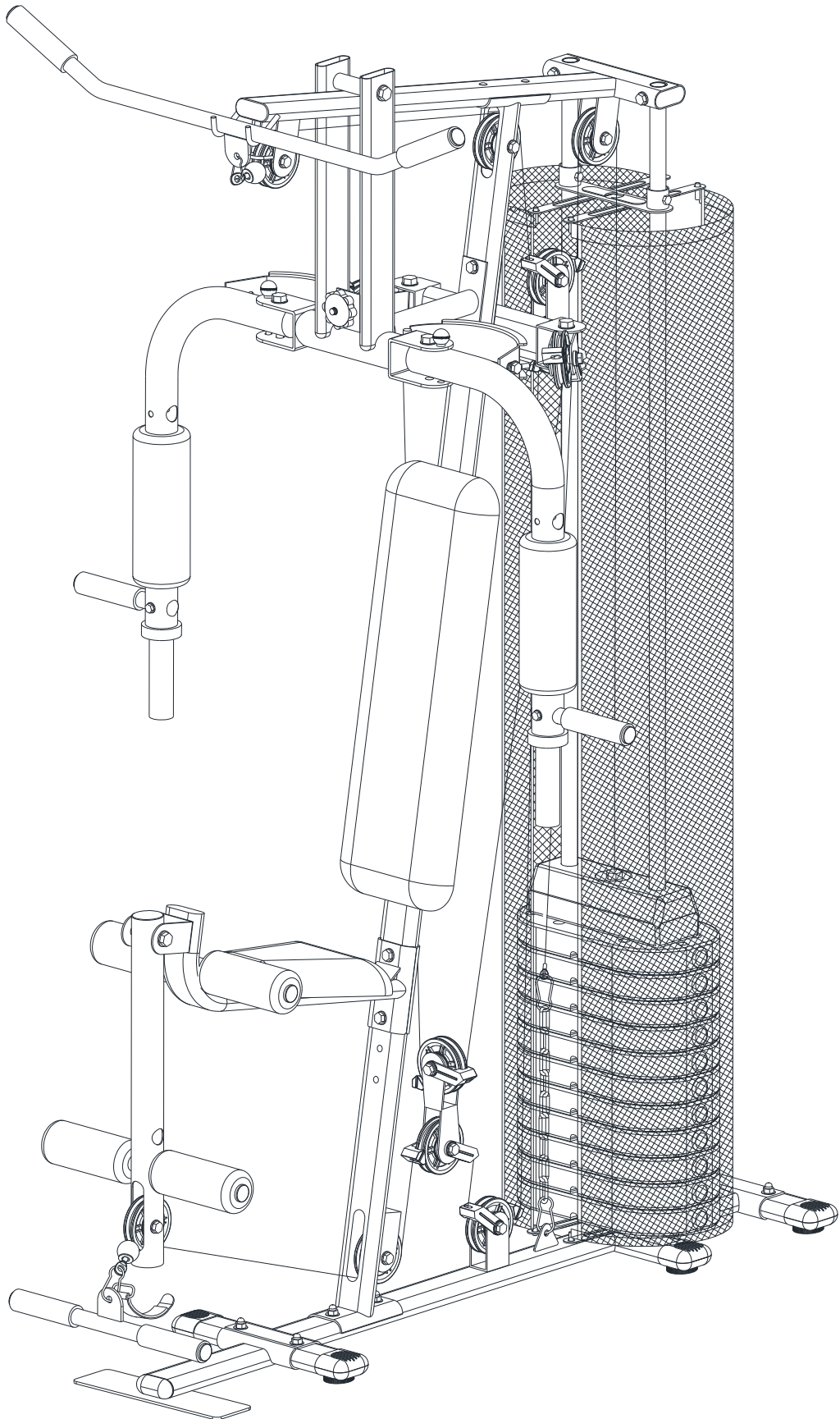

CHECK LIST

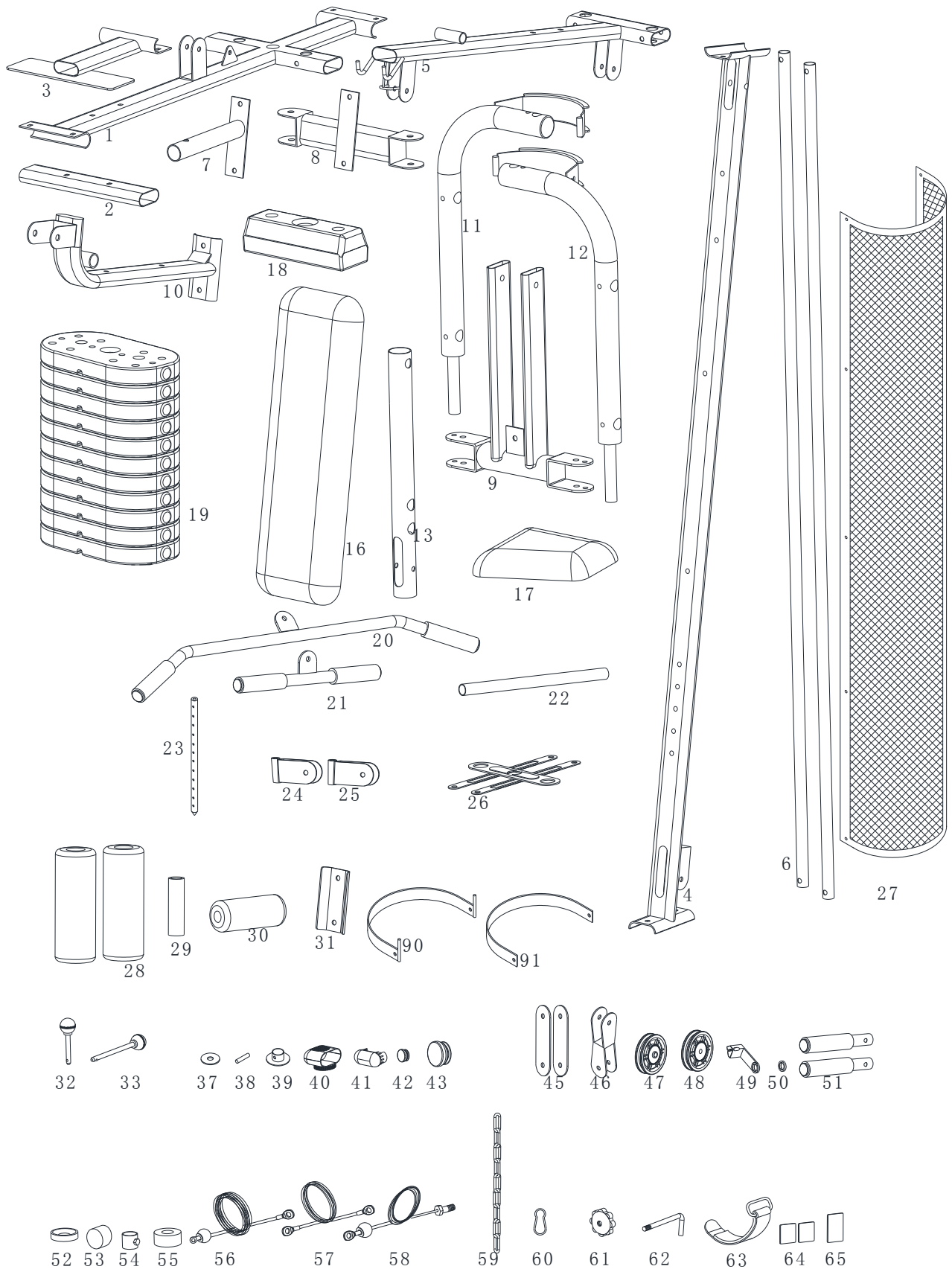





















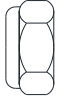

LIST OF COMPONENTS

NO.	DESCRIPTION	Q'TY	NO.	DESCRIPTION	Q'TY
1	Main Base	1	50	Inner tube of pulley	15
2	Stabilizing Base	2	51	Hand grip	2
3	Anti-lift board	1	52	Hollow cap	2
4	Front vertical beam	1	53	Foot cap	1
5	Upper beam	1	54	buffer of guidance	2
6	Chrome Guides	2	55	buffer	2
7	Resist bar	1	56	Cable III 4100L	1
8	Balance rod	1	57	Cable I 3100L	1
9	press tube	1	58	Cable II 2415L	1
10	Seat Support	1	59	Chain (9links)	1
11	Right butterfly arm	1	60	Hook	4
12	Left butterfly arm	1	61	Knob 3/8"-16UNC-28L	1
13	Leg extension rod	1	62	Fixing hook	1
16	Backrest	1	63	Ankle strap	1
17	Seat	1	64	Buffer	2
18	Upper selector	1	65	Buffer	1
19	Lower selector	11	66	Bushing	8
20	Upper pulley bar	1	67	Bushing	2
21	Lower pulley bar	1	68	Bushing	2
22	Foam holder	2	69	Anti-loosen nut M6*1*6T	20
23	Selector guide rod	1	70	Anti-loosen nut M8*1.25*8T	2
24	Left pulley bracket	1	71	Anti-loosen nut M10*1.5*10T	22
25	Right pulley bracket	1	72	Anti-loosen nut M12*1.75*12T	6
26	Cover fixing plate	2	73	Domed nut M8x1.25x15L	8
27	Shroud	2	74	Flat washer D14*D6.5*0.8T	42
28	Big foam D47*D90*250L	2	75	Flat washer D19xD8.3x1.6t	12
29	Small foam D23*D35*127L	8	76	Flat washer D20*D11*2T	46
30	Foam D23*D70*170L	4	77	Flat washer D24*D13.5*2.5T	12
31	Reinforcing board	1	78	square neck bolt M8x1.25x45L	8
32	Ball pin	2	79	Hex bolt M6*1*15L	22
33	Weight selection pin	1	80	Hex bolt M8*1.25*60L	2
37	Weight fixing washer	1	81	Hex bolt M10*1.5*45L	4
38	Weight fixing pin	1	82	Hex bolt M10*1.5*50L	5
39	Weight fixing cover	1	83	Hex bolt M10*1.5*55L	2
40	Foot cap (oval)	6	84	Hex bolt M10*1.5*60L	7
41	End cap (oval)	5	85	Hex bolt M10*1.5*65L	1
42	End cap (round)	14	86	Hex bolt M10*1.5*85L	5
43	End cap (round)	4	87	Hex bolt M12*1.75*80L	5
45	Pulley plate	2	88	Hex bolt M12*1.75*135L	1
46	Double pulley bracket	1	89	Hex bolt M10*1.5*25L	2
47	Raised pulley	9	90	Reforcing plate set	4

48	Flat pulley	3	91	Reforcing plate	6
49	Pulley guide plate	15			

Screw bag

78		M8x45	x8	66		D29*D12.1*9T	x8
79		M6x1x15	x20	67		D18*D10.2*24T	x2
80		M8x60	x2	68		D18*D10*18.5T	x2
81		M10x45	x4	69		M6*1*6T	x20
82		M10x50	x5	70		M8*1.25*8T	x2
83		M10x55	x2	71		M10*1.5*10T	x22
84		M10x60	x7	72		M12*1.75*12T	x6
85		M10x65	x1	73		M8x15	x8
86		M10x85	x5	74		D14*D6.5*0.8T	x40
87		M12x80	x5	75		D19*D8.3*1.6T	x12
88		M12x135	x1	76		D20*D11*2T	x46
89		M10x25	x2	77		D24*D13.5*2.5T	x12

STEP 1

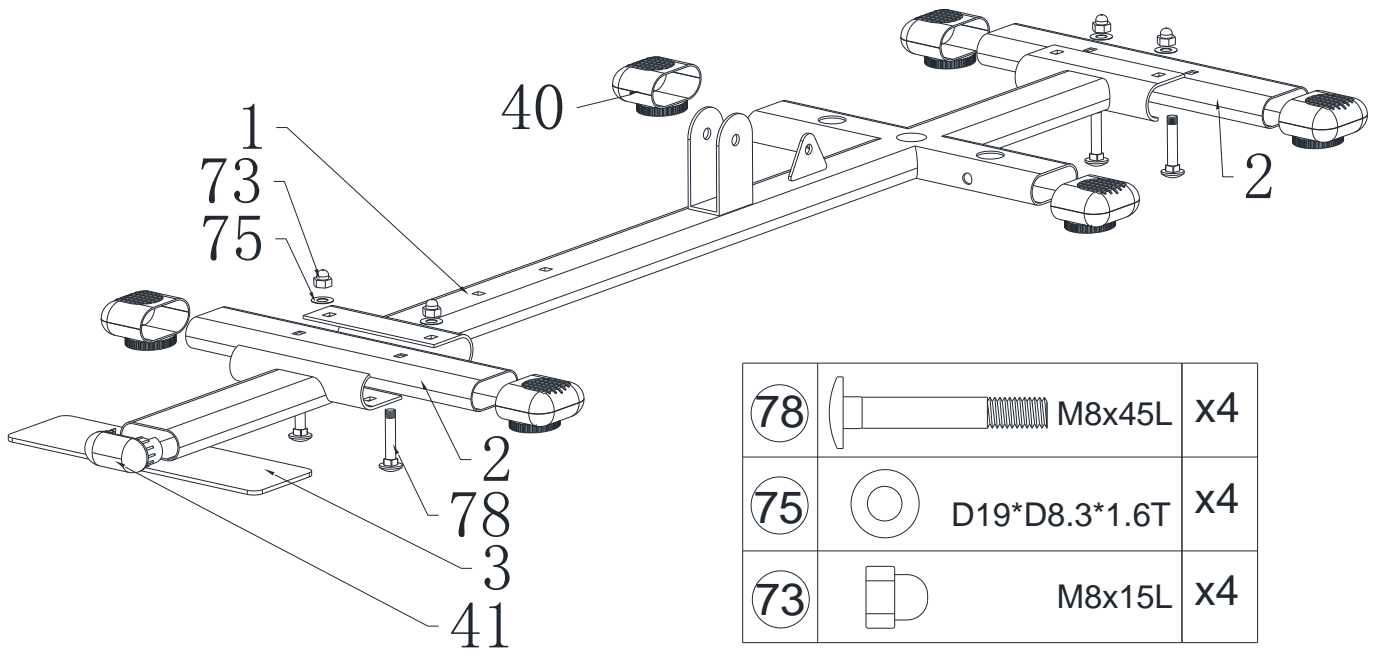







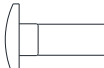

78		M8x45L	x4
75		D19*D8.3*1.6T	x4
73		M8x15L	x4

FIG.1

STEP 2

78		M8x45L	x2
75		D19*D8.3*1.6T	x2
73		M8x15L	x2
86		M10x1.5x85	x2
76		D20*D11*2T	x4
71		M10*1.5*10T	x2

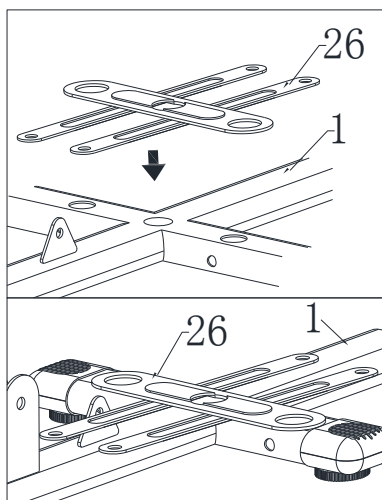
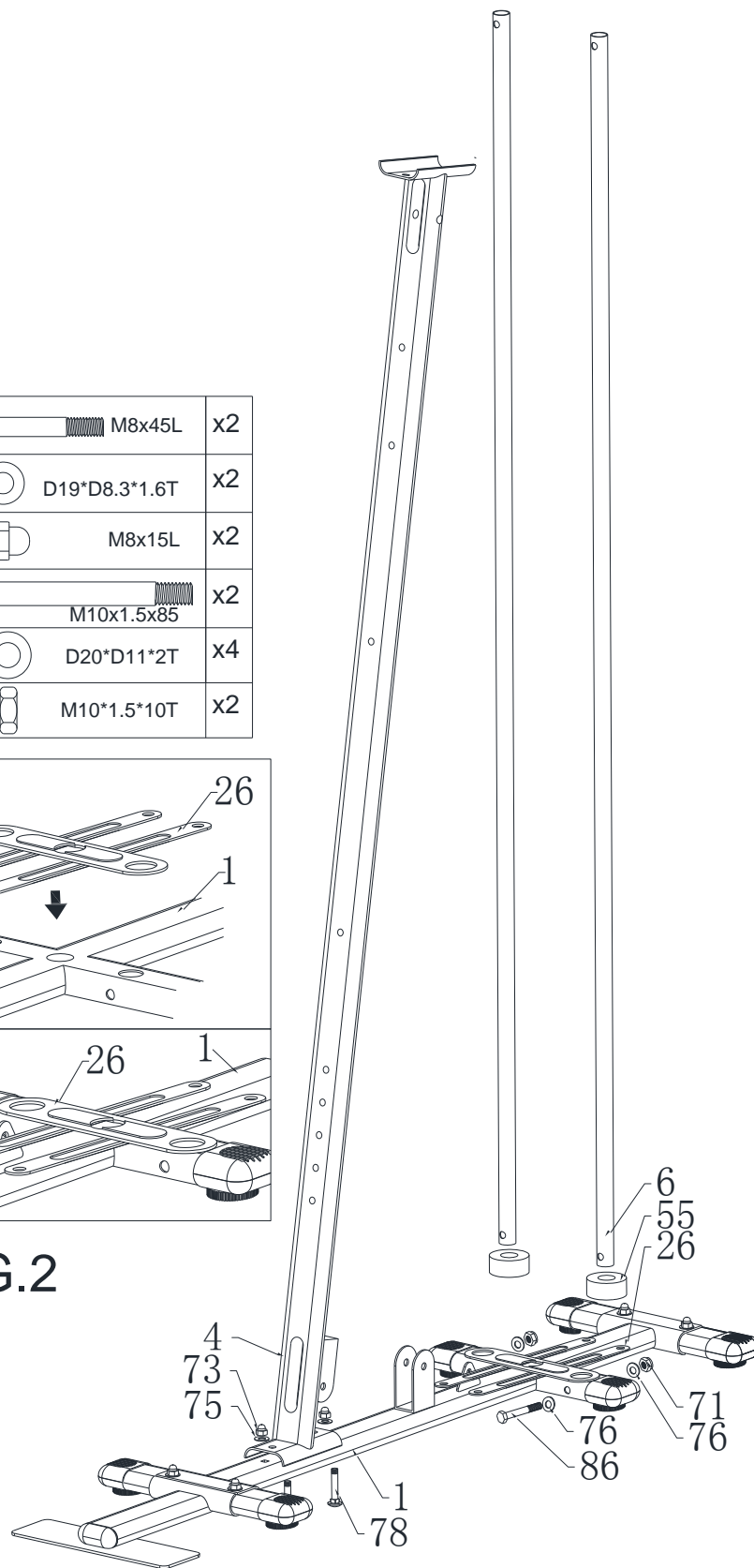
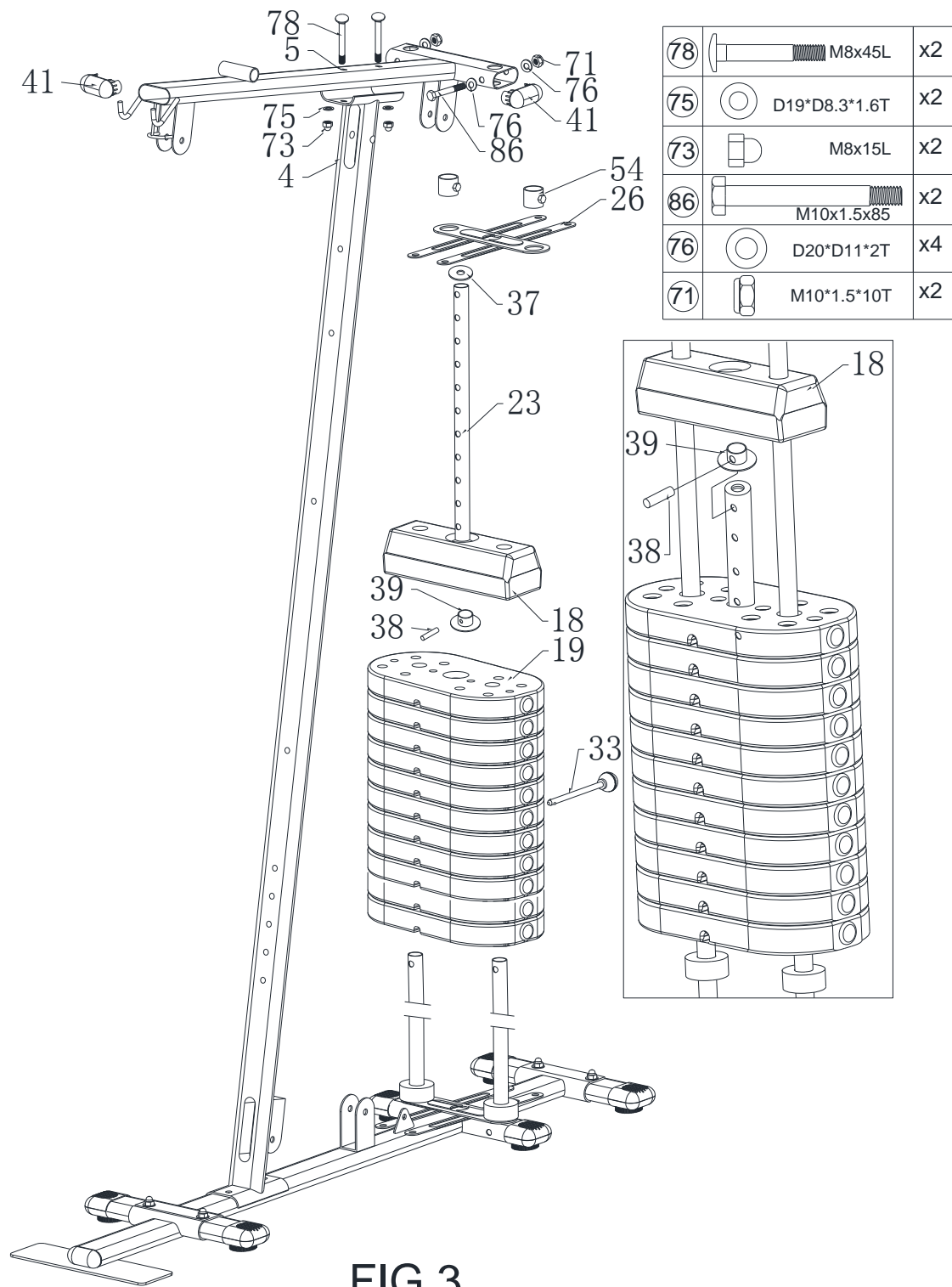

FIG.2



STEP 3



STEP 4

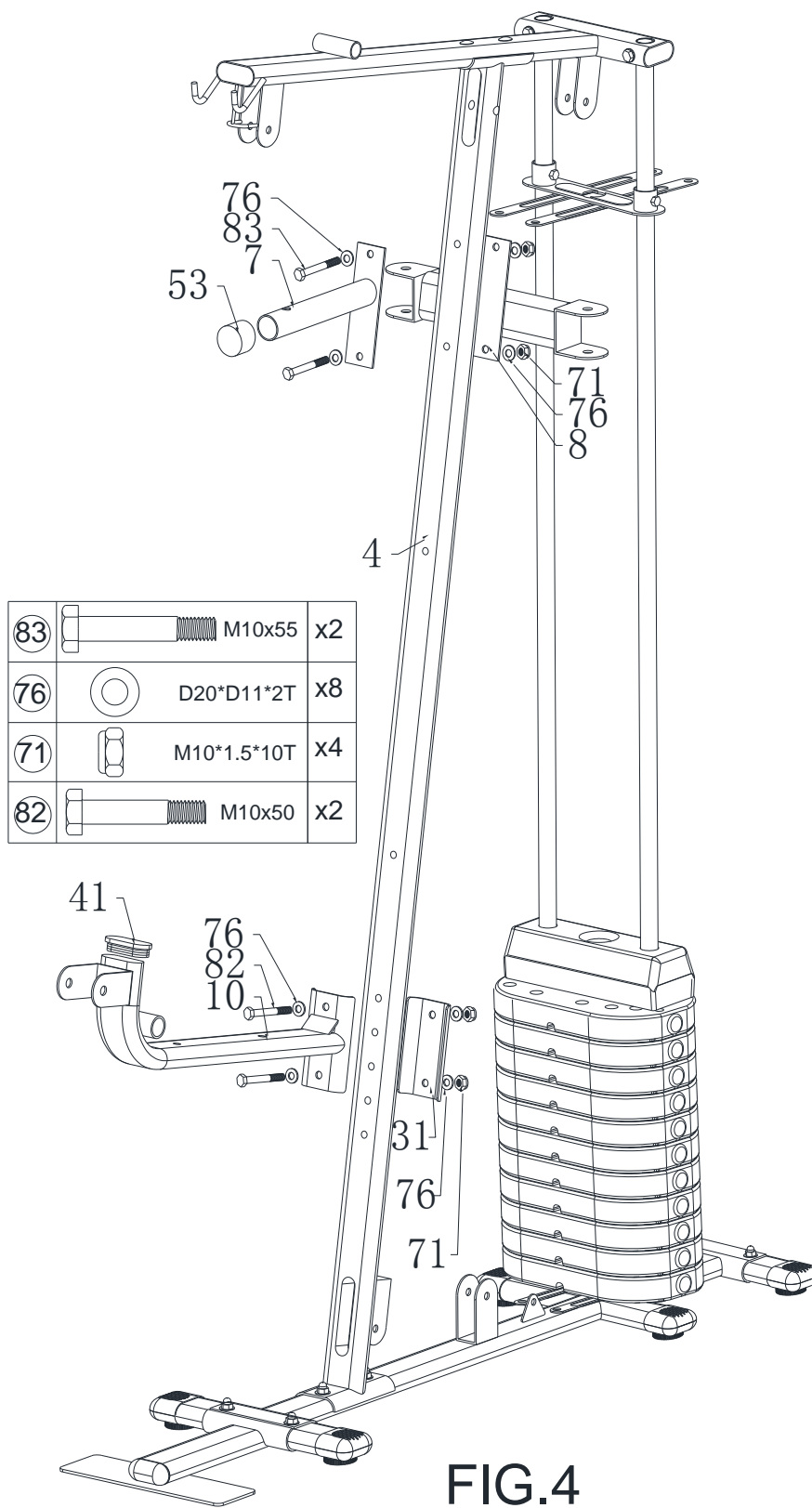

STEP 5

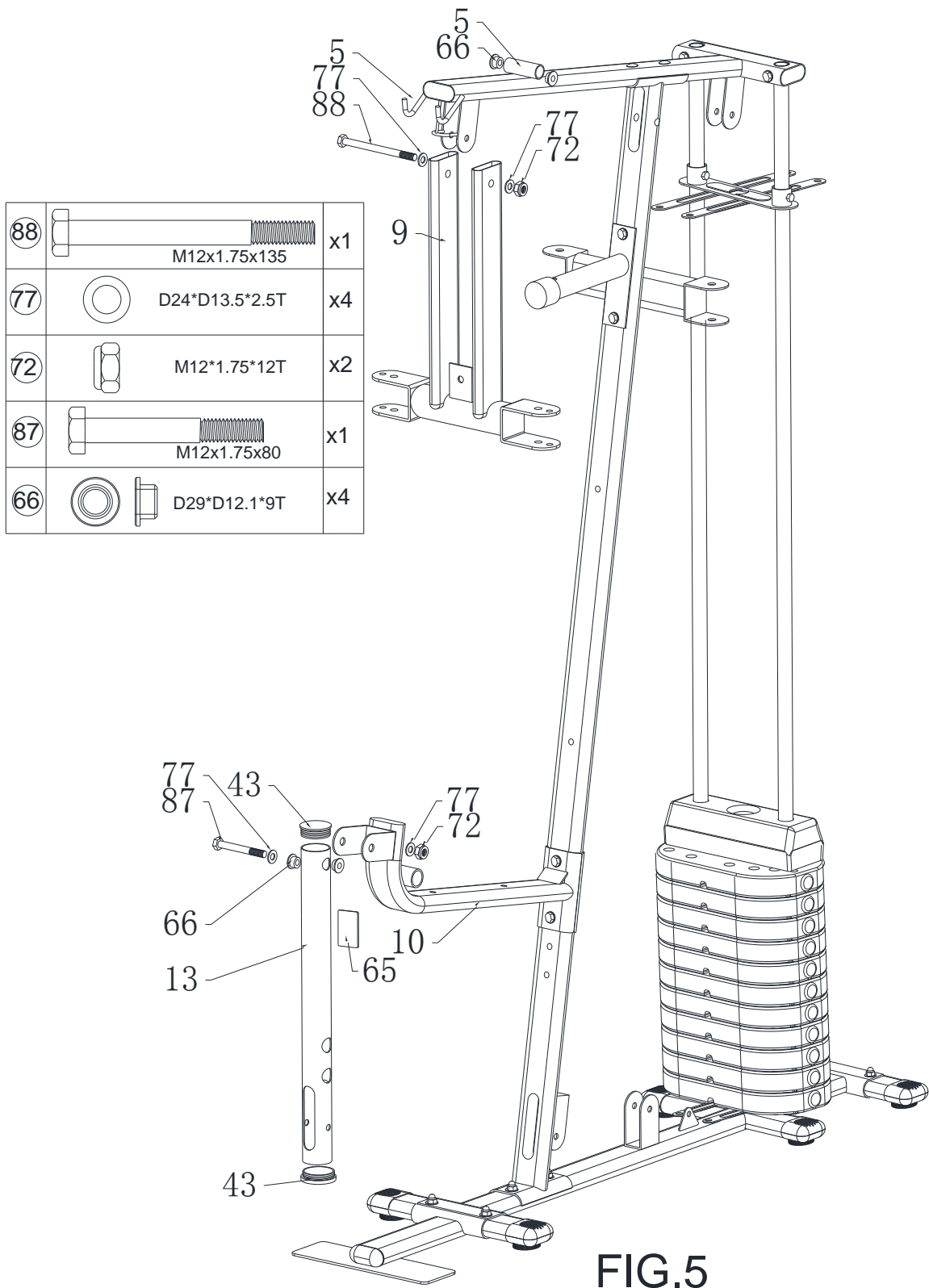

STEP 7

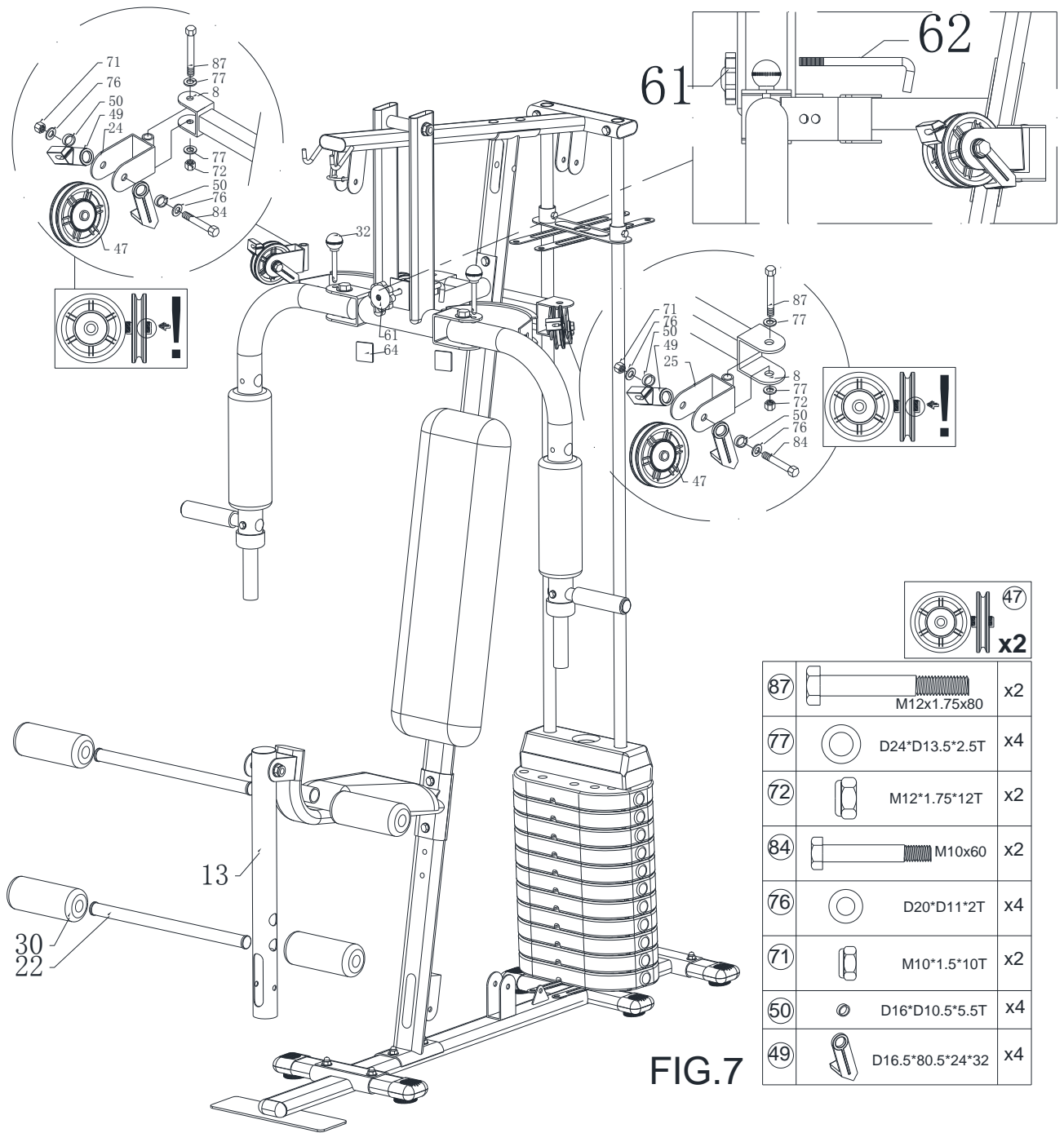

87		M12x1.75x80	x2
77		D24*D13.5*2.5T	x4
72		M12*1.75*12T	x2
84		M10x60	x2
76		D20*D11*2T	x4
71		M10*1.5*10T	x2
50		D16*D10.5*5.5T	x4
49		D16.5*80.5*24*32	x4

STEP 8

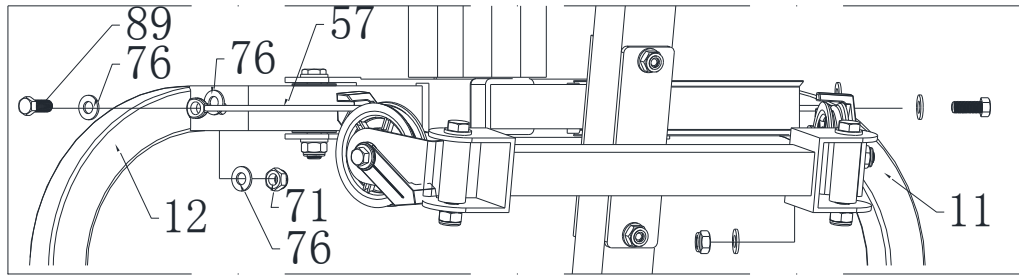

89		M10x25	x2
76		D20*D11*2T	x10
71		M10*1.5*10T	x4
84		M10x60	x2
50		D16*D10.5*5.5T	x4
49		D16.5*80.5*24*32	x4

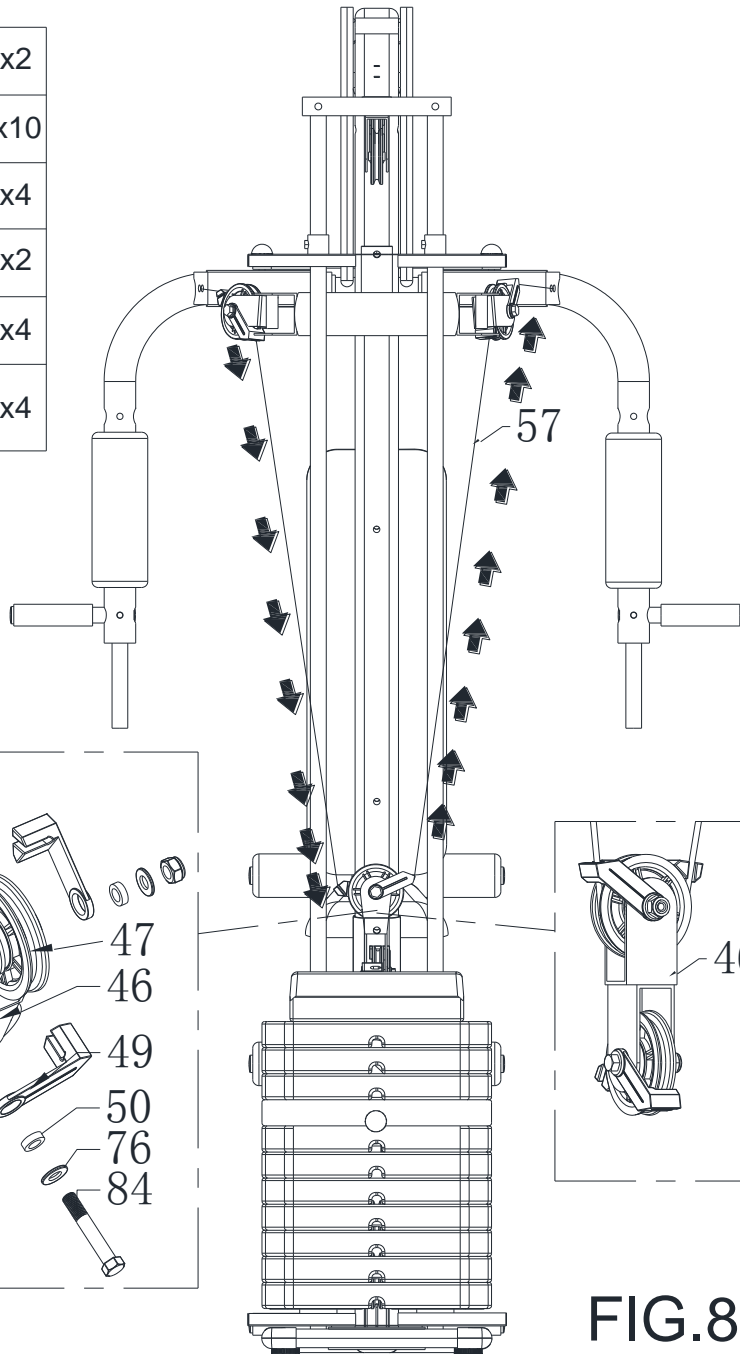
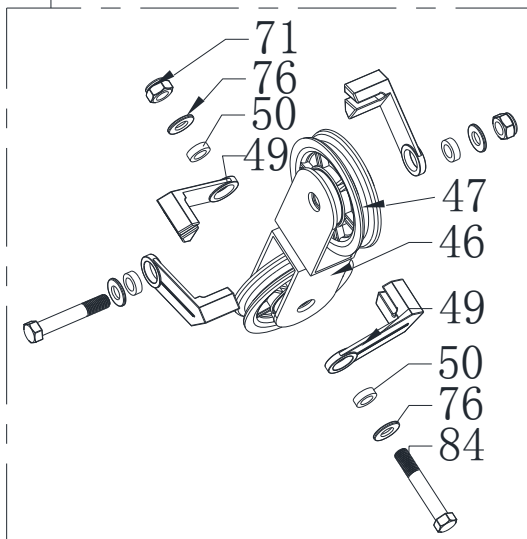
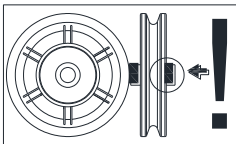
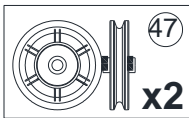

FIG.8

STEP 9

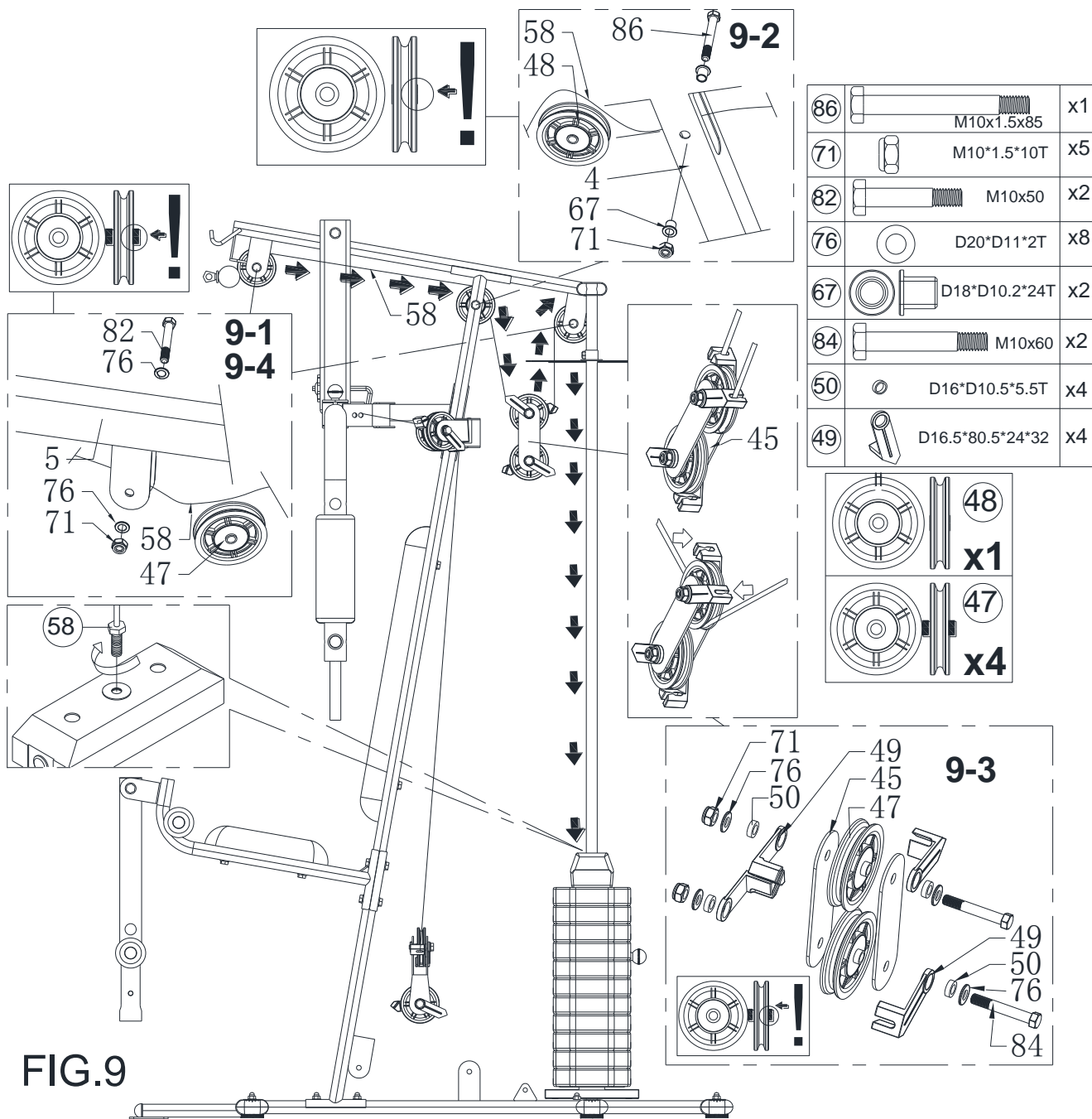
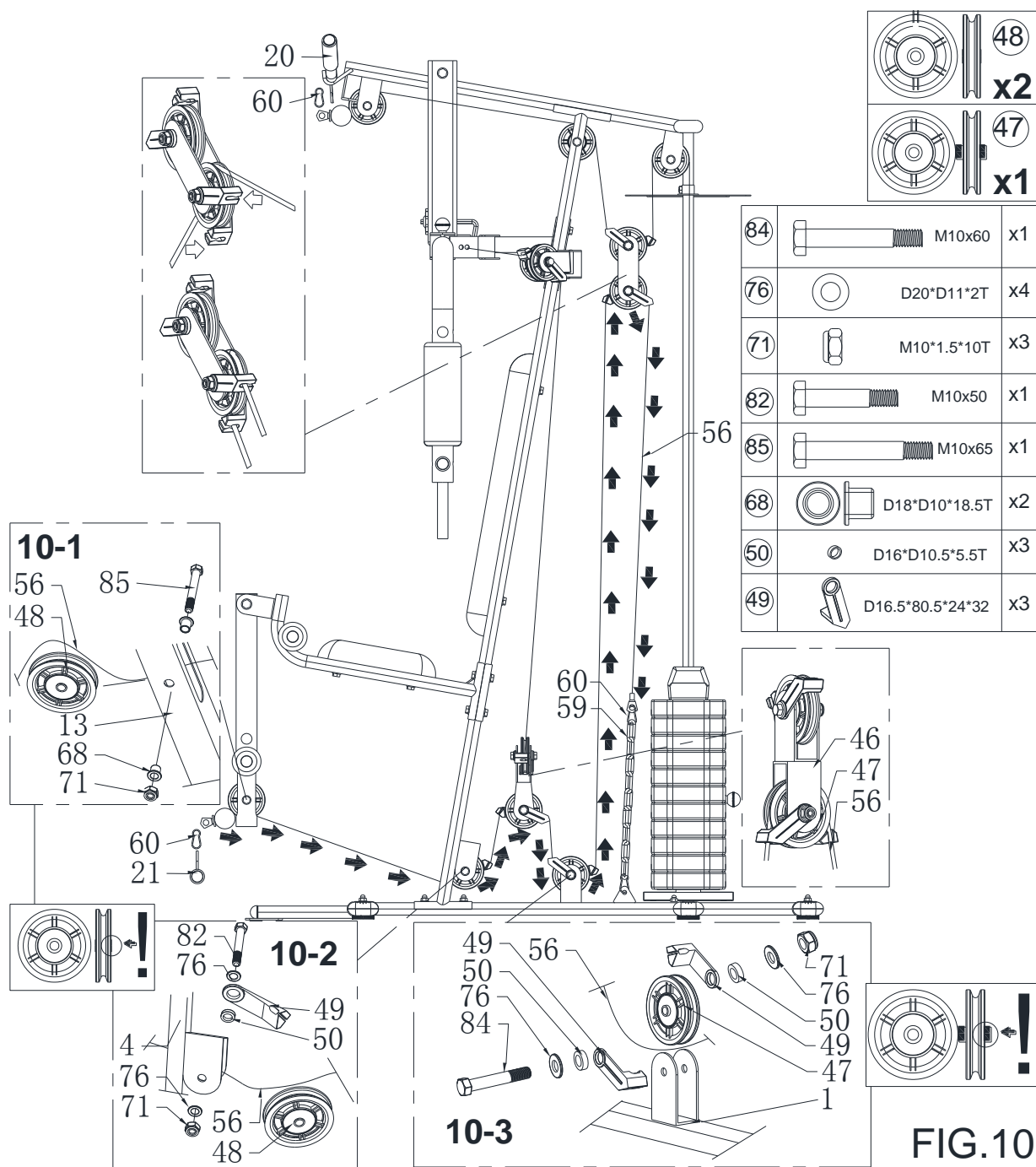
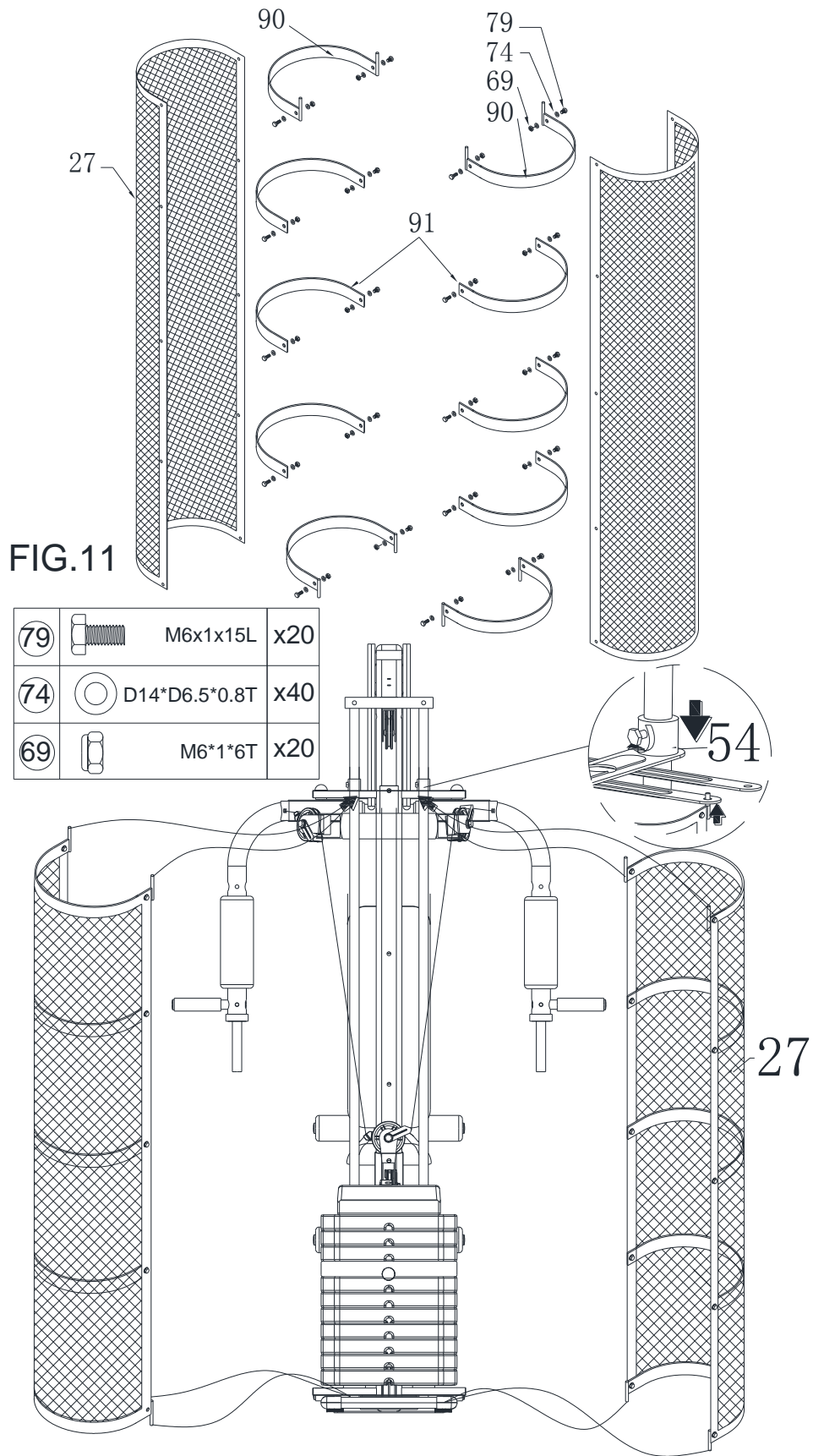

FIG.9

STEP 10



STEP 11



Exploding drawing

