

1239

MULTIFUNCTION TRAINER

KH-31901

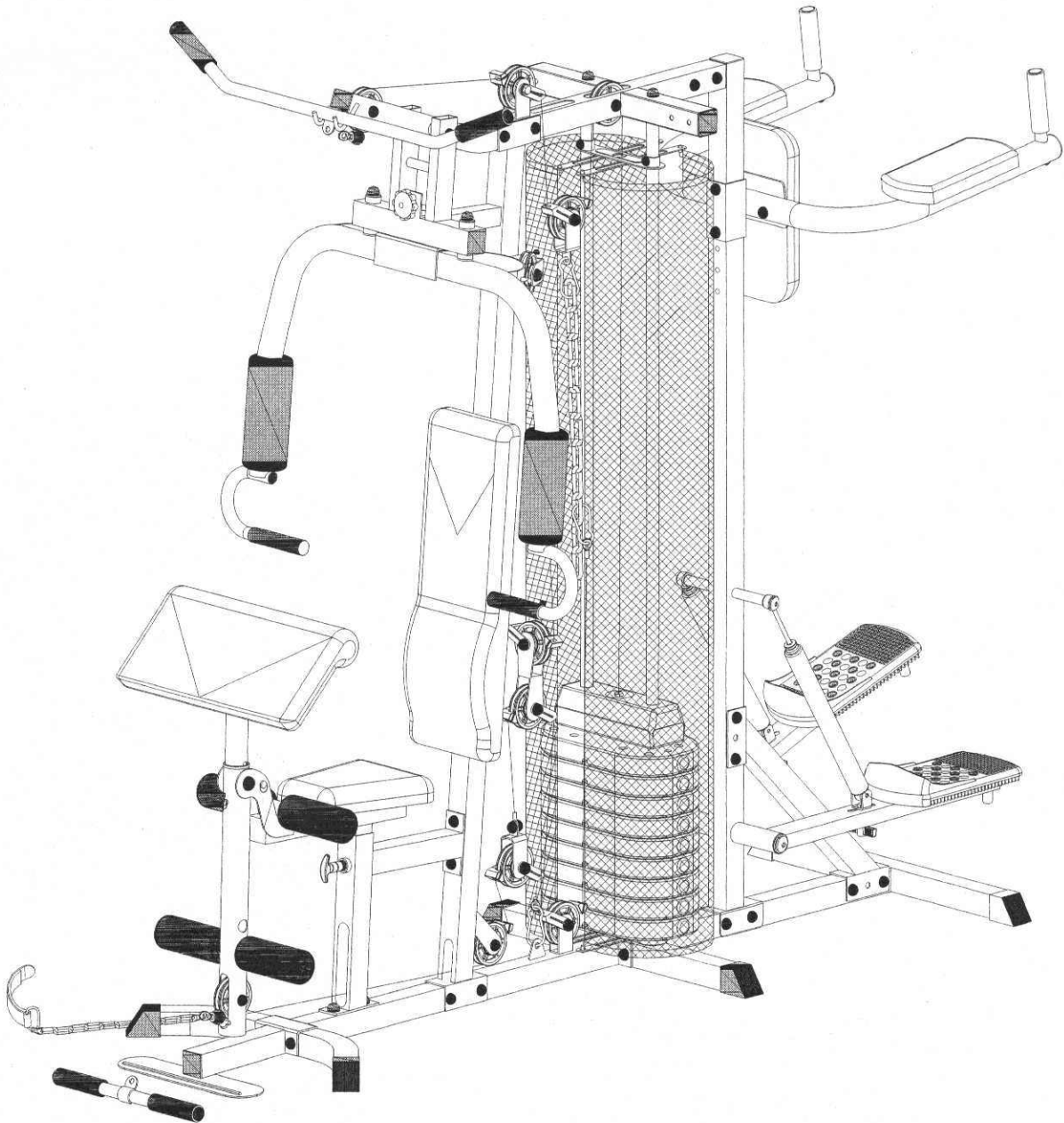





PART LIST



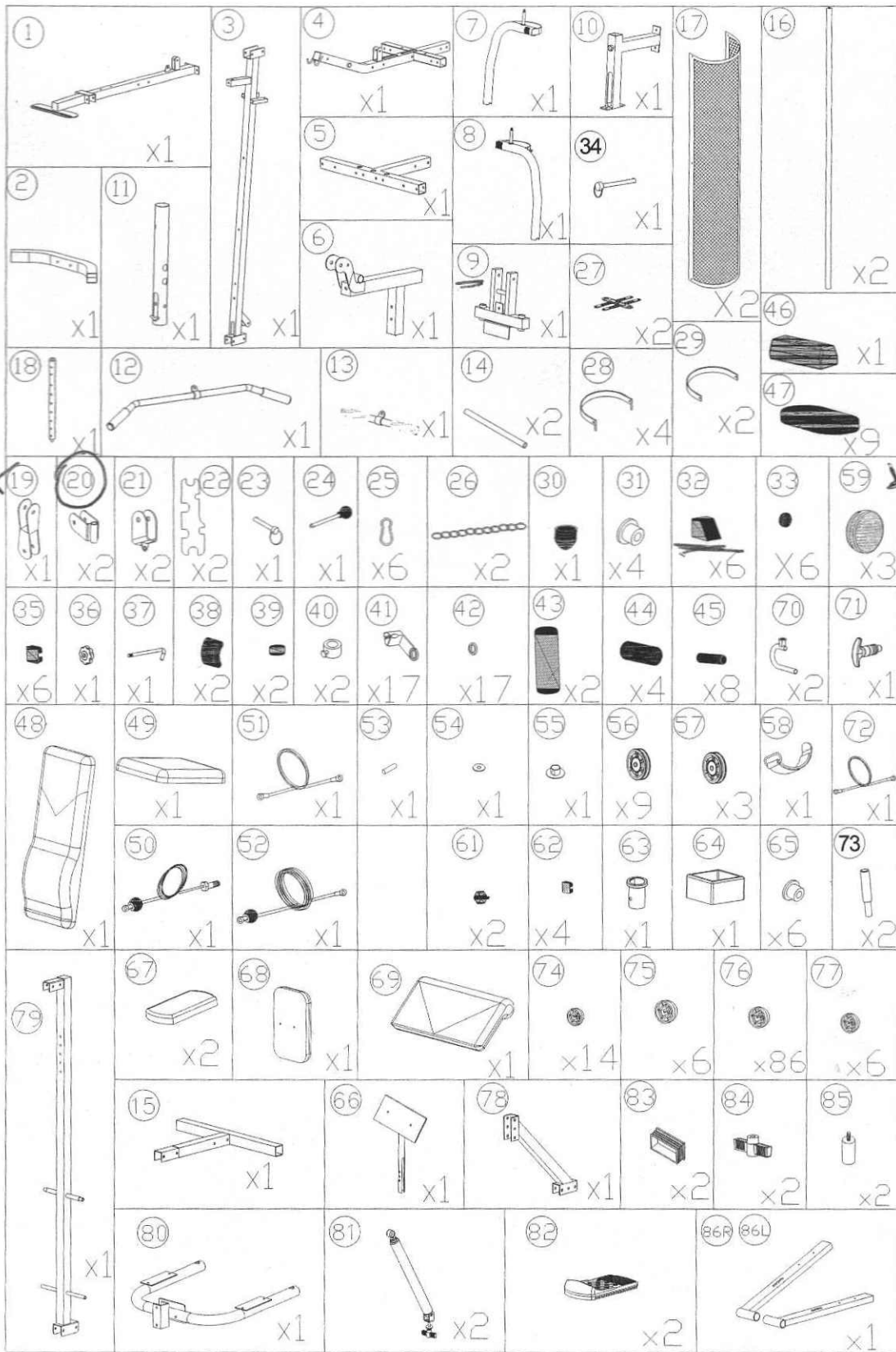

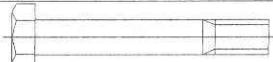
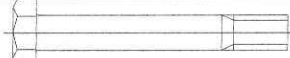
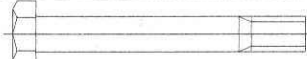
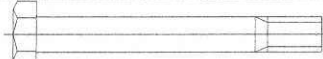
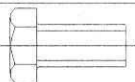
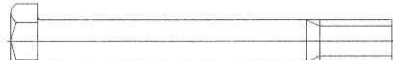
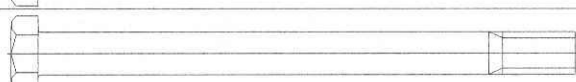
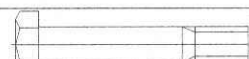
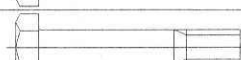

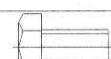

Part no	description	Q'ty	Part no.	description	Q'ty
1	Base frame	1	44	foam	4
2	Front stabilizer	1	45	foam	6
3	Front vertical support	1	46	Upper weight plate	1
4	Upper beam	1	47	Lower weight plate	9
5	Cross stabilizer	1	48	backrest	1
6	Seat support	1	49	seat	1
7	Right butterfly arm	1	50	Cable (weight—upper beam)	1
8	Left butterfly arm	1	51	Cable (butterfly arms)	1
9	Butterfly arm support	1	52	Cable (leg curler)	1
10	Seat tube support	1	53	Weight pin	1
11	Leg curler	1	54	Weight washer	1
12	Upper pulling bar	1	55	Weight sleeve	1
13	Lower pulling bar	1	56	Raised pulley	9
14	Foam roller	2	57	Flat pulley	3
15	Rear stabilizer	1	58	Ankle strap	1
16	Weight guidance rod	2	59	Round cap Φ 50.8	3
17	Weight protector	2	60	xxx	x
18	Weight selecting bar	1	61	Rubber buffer	2
19	Double pulley support	1	62	Square plug 25*25	4
20	Single pulley support	2	63	Insert plug	1
21	Single pulley welding set	2	64	Square hollow cap	1
22	Spanner	2	65	Bushing D18xD10X14.5	6
23	pin	1	66	Arm curl pad support	1
24	selecting rod	1	67	Arm curl pad	1
25	hook	6	68	Small back pad	1
26	Chain (11 links)	2	69	Arm curl pad	1
27	Cross plate	2	70	Butterfly hand grip	2
28	Cover fixing plate with rod	4	71	Spring knob	1
29	Cover fixing plate	2	72	Cable	1
30	End cap for weight selecting bar	1	73	Handlebar	2
31	Bushing D29XD12.1x9T	4	74	Screw cap M6	14
32	foot cap	4	75	Screw cap M12	6
33	Round plastic cap D1 x17.5L	6	76	Screw cap M10	86
34	Pin D9.4*70L	1	77	Screw cap M8	6
35	Square plastic cap 50x50	6	78	Reinforce press tube	1
36	multi-angle knob	1	79	Rear vertical tube	1
37	Fixing hook	1	80	Arm tube welding set	1
38	Buffer R23x35x35	2	81	Hydraulic cylinder	2
39	Round buffer D60xD26x2T	2	82	Pedal	2
40	Fixing sleeve	2	83	Square cap 30*60	2
41	Cable guidance plate	17	84	T KNOB	2
42	Plastic ring for cable guidance	17	85	Foot cap D32*60*M8	2
43	foam	2	86	Pedal support (L+R)	1set

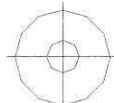
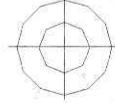
Part list of accessories screw bag:



Part no	description	Q'ty	Part no.	description	Q'ty
100	Bolt M10*75L	14	112	Bolt M10*60L	8
101	Flat washer D20*D11*2T	82	113	Bolt M12*150L	1
102	Nylon nut M10	39	114	Bolt 1/2"-13UNF *25L	4
103	Bolt M10*65L	9	115	Bolt M10*25L	1
104	Bolt M10*70L	14	116	Bolt M6*15L	14
105	Hex bolt M8*20L	6	117	Flat washer D14*D6.5*0.8T	30
106	Flat washer D24*D13.5*2.5T	4	118	Nylon nut M6	16
107	Nylon nut M12	2	119	Bolt M10*55L	1
108	Bolt M10*95L	2	120	Flat washer D28*D14*2T	4
109	Bolt M12*80L	1	121	Spring washerD15.4*D8.2*2T	4
110	Flat washer D19*D8.5*1.6T	2	122	Round head screw M6*1*55L	4
111	Flat washer D28*D8.5*3T	6			



103	M10*1.5*65L		X9
104	M10*1.5*70L		X14
100	M10*1.5*75L		X14
108	M10*1.5*95L		X2
114	1/2"-13UNC*25L		X4
109	M12*1.75*85L		X1
113	M12*1.75*150L		X1
112	M10*1.5*60L		X8
119	M10*1.5*55L		X1
105	M8*1.25*20L		X6
122	M6*1*55L		X4
115	M10*1.5*25L		X1
116	M6*1*15L		X14

117	D14*D6.5*0.8T		X30	111	D28*D8.5*3.0T		X6
120	D28*D14*2.0T		X4	121	D15.4*D18.2*2T		X4
101	D20*D11*2T		X82	118	M6*1*6T		X16
106	D24*D13.5*2.5T		X4	102	M10*1.5*10T		X39
110	D19*D8.5*1.6T		X2	107	M12*1.75*12T		X2

INSTRUCTION ASSEMBLY:
STEP 1.

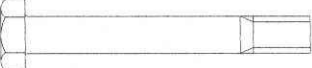
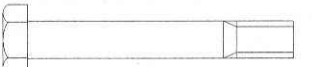
102		M10*1.5*10T	×4
101		D20*DI1*2T	×8
100		M10*1.5*75L	×2
104		M10*1.5*70L	×2

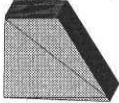
35		×1
32		×4

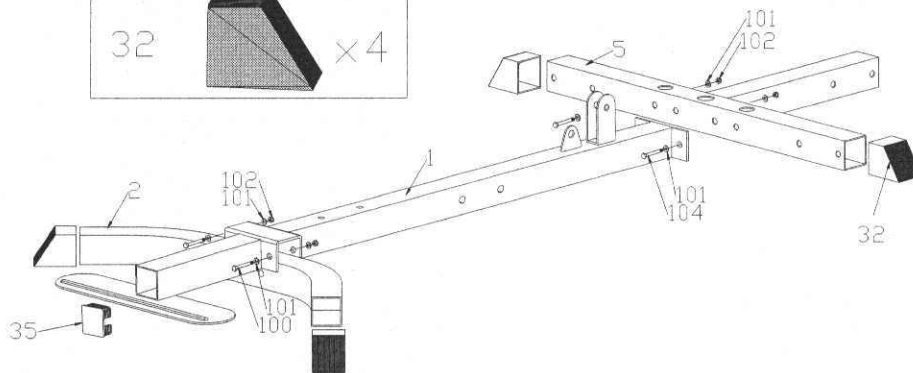

(1) Fix the front stabilizer (2) and cross stabilizer (5) onto the base frame (1) by using 4* foot caps (32), 1* square plastic cap (35), 2* bolts (104), 2* bolts (100), 8* flat washers (101) and 4* nylon nuts (102).

STEP 2.

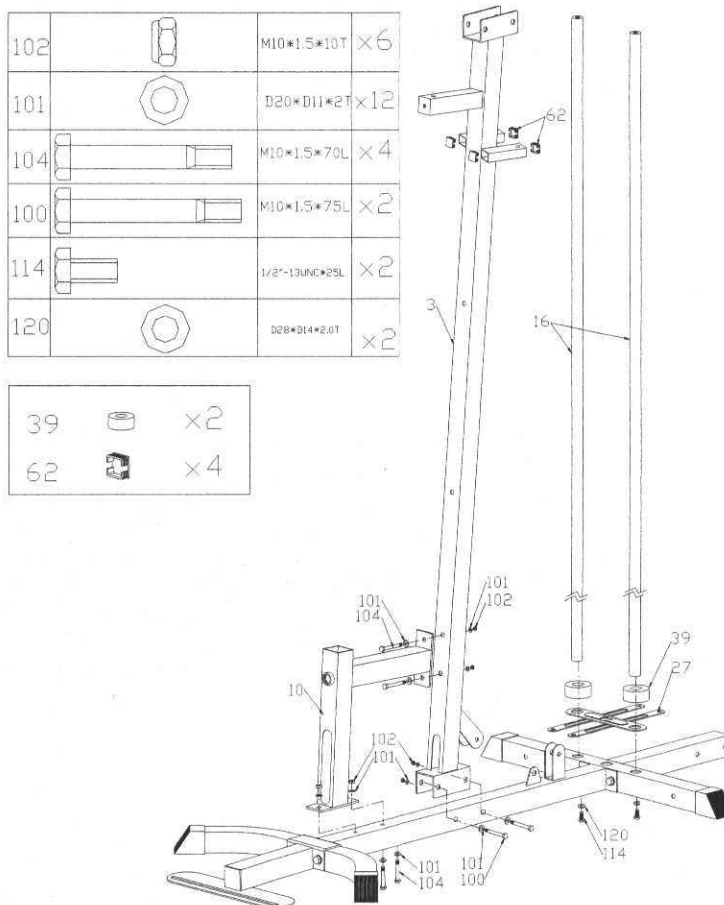

- (1) Assemble the seat tube support (10) to the base frame (1) with 2*bolts (104), 4*flat washers (101) and 2*nylon nuts (102). Then after fixing the front vertical support (3) to the base frame (1) by using 2*bolts (100), 4*flat washer (101) and 2*nylon nuts (102), assemble the seat tube support (10) with the front vertical support (3) by using 2*bolts (104), 4*flat washers (101) and 2*nylon nut (102).
- (2) Attach the weight guidance rod (16), first thread the cross plate (27) and two buffers (39) from the bottom, then assemble them to the rear stabilizer through 2 bolts (114) and 2* flat washers (120).
- (3) Fix the square plug(62) onto the front vertical support (3).

STEP 3

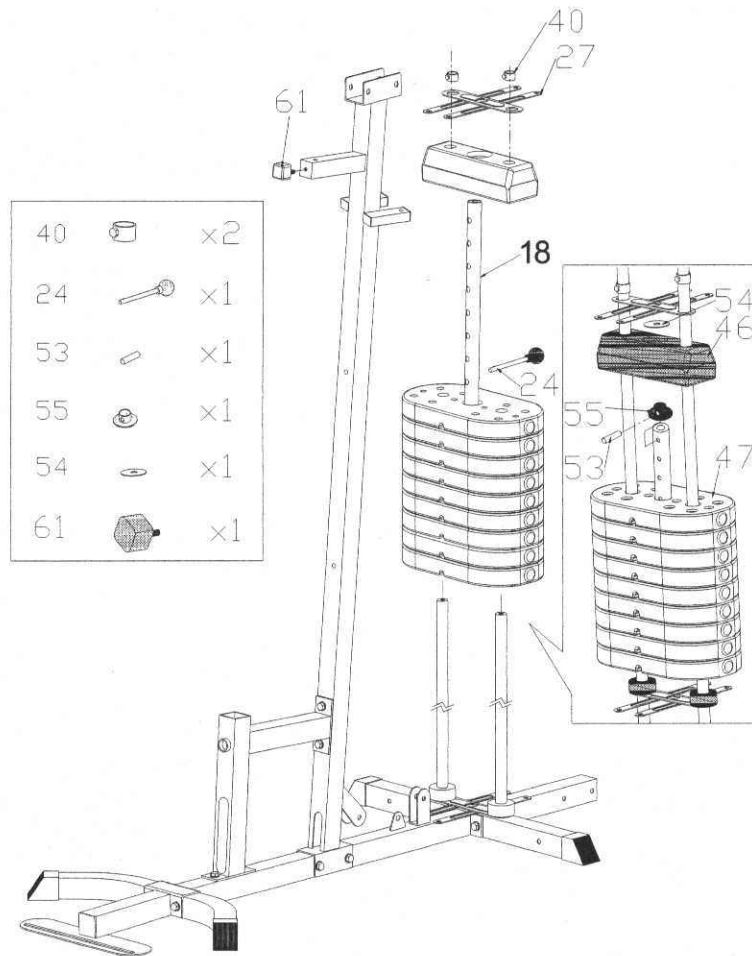

- (1) Continuing to assemble 9*lower weight plate (47) and 1 upper weight plate (46) through the weight guidance rod (16), inset the weight selector (18) through the hole of weights and fix the weight sleeve (55) down from the upper weight (46) by means of weight pin (53) and the weight washer (54). Finally put the cross plate (27) and 2 fixing sleeves (40) on the upper bottom of the weight guidance rod (16).

STEP 4

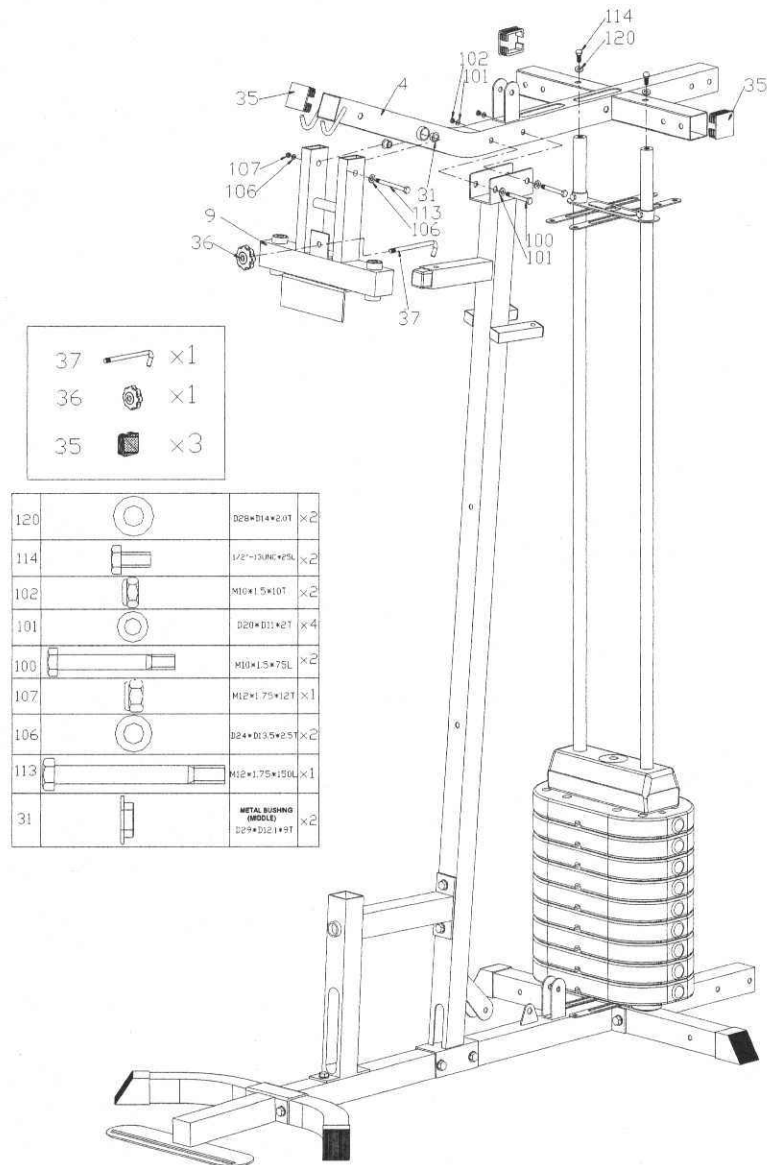

- (1) Assemble the upper beam (4) onto the front vertical support (3), weight guidance rod (16) by using 3 square plastic caps (35), sequentially with 2 bolts (100), 4 flat washers (101), 2 nylon nut (102); 2 bolts (114), 2 flat washers (120).
- (2) Fix the butterfly arm support (9) onto the upper beam (4) by using 2 bushing (31), 1 bolt (113), 2 flat washers (106) and 1 nylon nut (107), and then fix the multi-angle knob (36) and 1 fixing hook (37) onto the butterfly arm support (9).

STEP 5

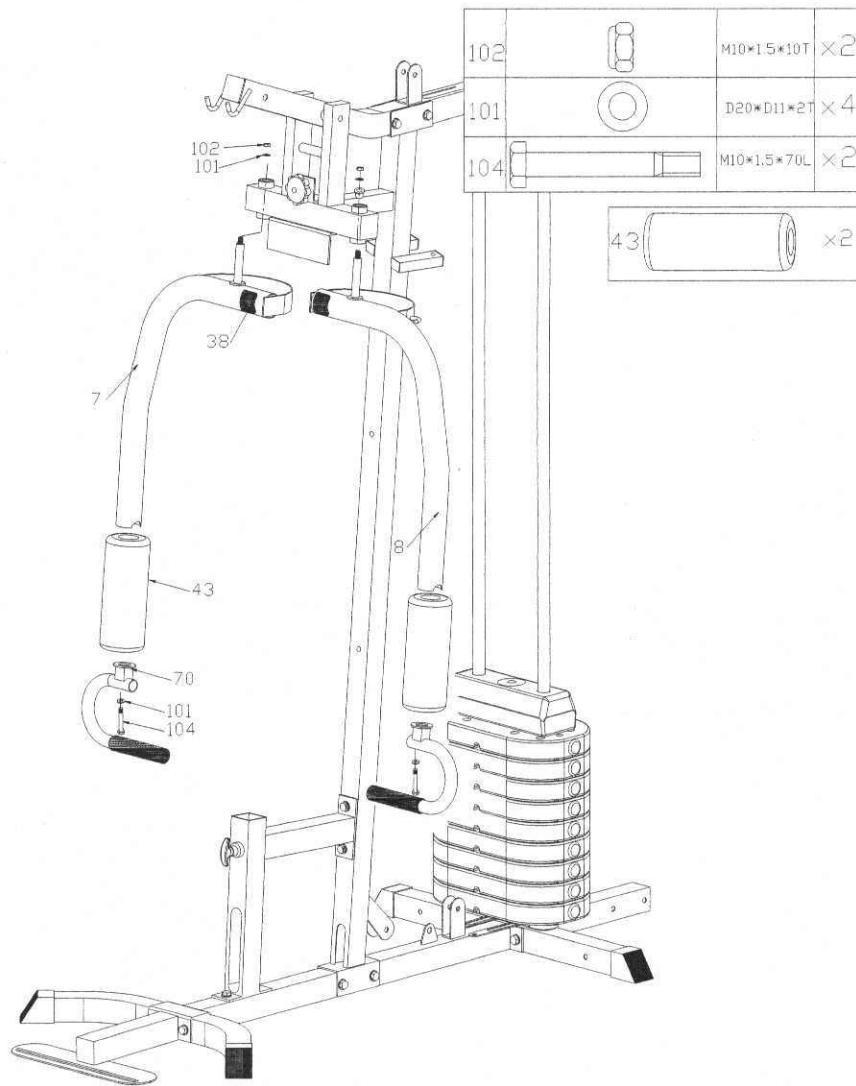

- (1) attach the 2 buffer (38) onto right & left butterfly arm (7&8), then fix the right & left butterfly arm to the butterfly arm support (9) by using 2 flat washers (101) and 2 nylon nut (102).
- (2) Slide the foam (43) onto the butterfly arm, then assemble the butterfly hand grip (70) to the butterfly arm by using the bolt (104) and flat washer (101).

STEP 6

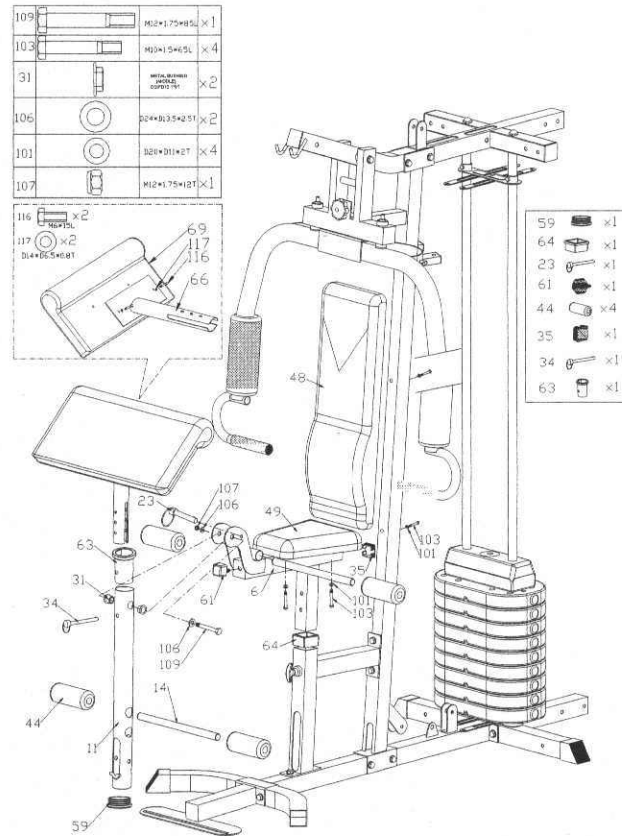

- (1) Insert a square hollow cap (64) and seat support (6) into the seat tube support (10). After that fix the buffer (61) and the square plastic cap (35) in the corresponding place of the seat support.
- (2) Fix the backrest (48) and the seat (49) to their corresponding parts by the flat washer (101) and bolts (103).
- (3) Attach the arm curl pad (69) onto the pad support (66) by means of 2 bolt (116) and 2 flat (117).
- (4) Fix the insert plug (63) and arm curl pad support (66) into the leg curler (11). Then fix the leg curler (11) attach to the seat support (6) by using 2*bushing (31), 2 flat washer (106) ,1*nylon nut (107), 1*bolt (109) and 1*round plastic cap (59) and 1 pin(34).
Place the pin (23) into the seat support (6).
- (5) Thread the foam roller (14) through the leg curler (11) and seat support (6), then coat the foam roller with the foam.

STEP 7

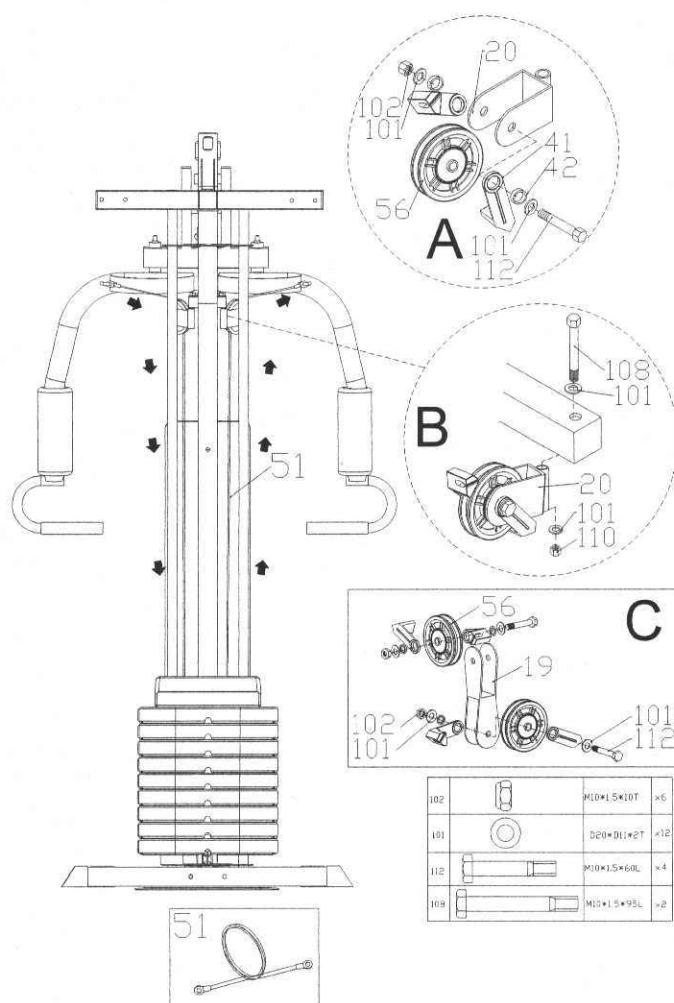

Connection of cable (butterfly arm) (51): the way going as drawing.

Hooking one of the cable to the right butterfly arm (7). At the same time, fixing the raised pulley (56) into the single pulley support (20) (FIG A) by using 1 bolt (112), 2 flat washer (101), 2 plastic ring for cable guidance (42), 2 cable guidance plate (41), 1 nut (102) and then assembly the single pulley support(20) with pulley (56) onto the right butterfly(FIG B) by means of 1 bolt (108), 2 flat washer (101) and 1 nut (110). Slide the other end of the cable along the pulley (56), after going downward and upwards through the double pulley support (19) which at the same time already fixing with the 2 raised pulley (56) using 2 bolt (112), 4 flat washer (101), 4 plastic ring for cable guidance (42), 2 cable guidance plate (41), 2 nut (102). And then the other end will be joined to the left butterfly arm (8).

STEP 8

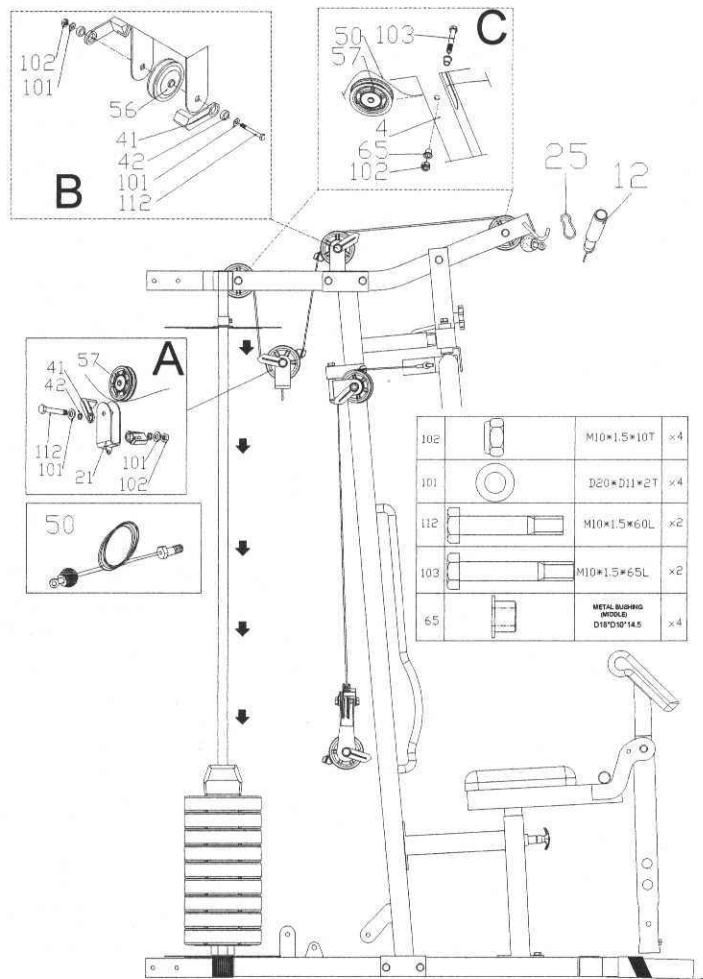

- (1) Connection of cable (50): hooking the end cable on the head of upper beam and then the way going as drawing. During the assembly, you must at the same time fix the 2 flat pulley (57) by using 1 bolt (103), 2 busing (65) and 1 nylon nut (102) and 1 raised pulley (56) onto the upper beam (FIG C) and also 1 raised pulley (56) onto the upper beam by using 1 bolt (112), 2 flat washer (101), 2 plastic ring (42), 2 cable guidance plate (41) (FIG B). and 1 flat pulley (57) between to the single pulley support (21) with the same bolt of FIG B.
- (2) The other end of cable will be jointed with the weight select bar.
- (3) Fix the upper pulling bar (12) with the upper beam by hook (25).

STEP 9

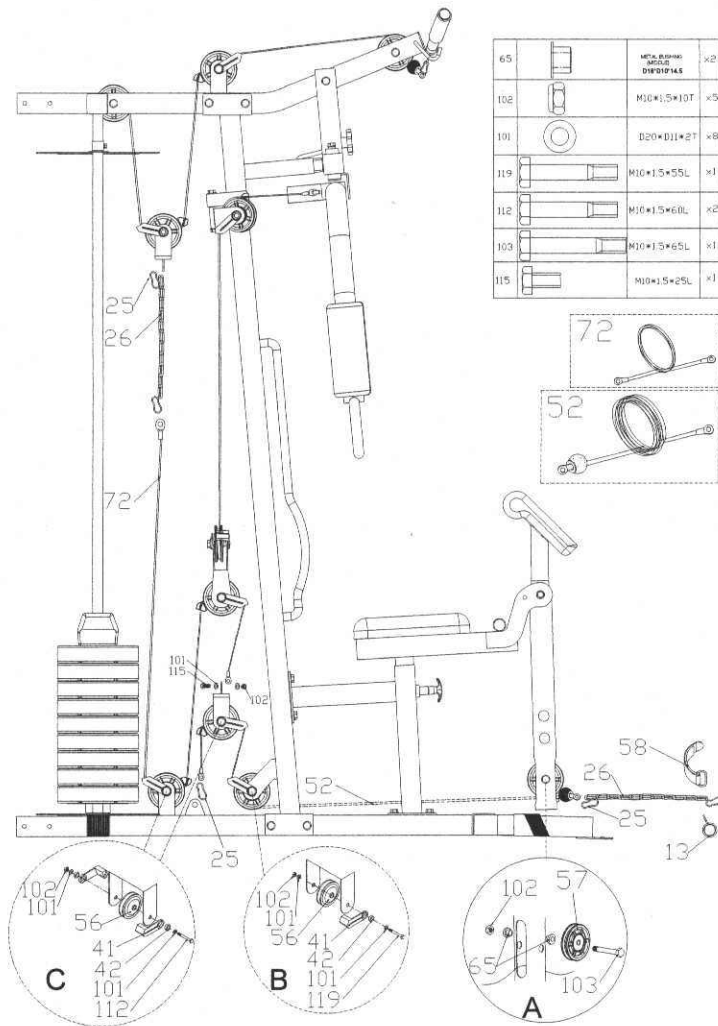

(1) Connection of cable (52): the way going as drawing. From the first pulley support on the leg curler (11), 1 flat pulley (57) is fixed inside the leg curler as exploded drawings (FIG A) by using 1 bolts (103), 2 bushings (65) and 1 nylon nut (102). After going downward and upward through 2 raised pulley (56) by 1 bolt (119), 2 flat washer (101), 1 plastic ring (42), 1 cable guidance (41), 1 nut (102) (FIG B & C), the other end will be joined to the main base by a spring hook (25).

(2) Connection of cable (72): the way going as drawing. Join one end of cable (72) and pulley (56) by 1*bolt (115), 2*flat washer (101) and 1*nylon nut (102). Through the pulley which already fixed, then going downward and upward through the relative pulleys(56), the other end will be joined with the cable (50) by using 1 chain (26) and 2 hook (25).

STEP 10

(1) Assemble 2 weight protector (17) around the weights by using 4 cover fixing plat with rod (28), 2 cover fixing plate (29), 12 nylon nuts (118), 12 bolts (116) and 24 flat washers (117).

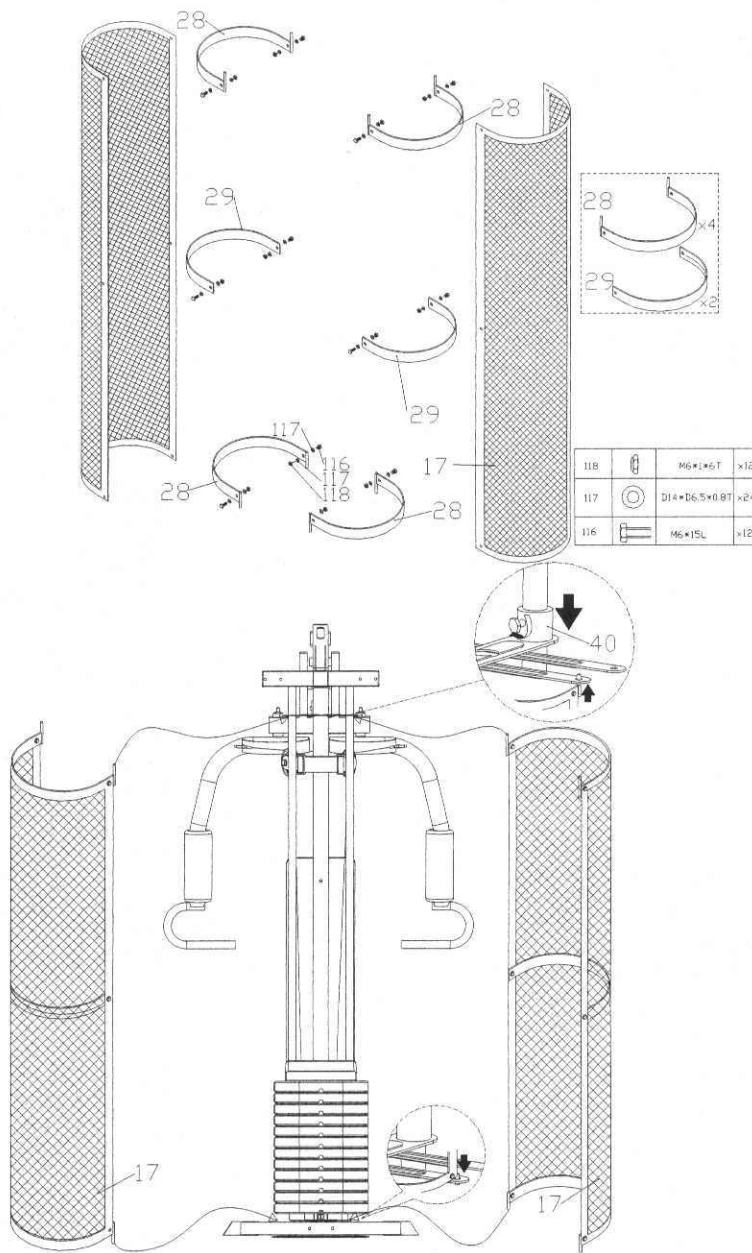



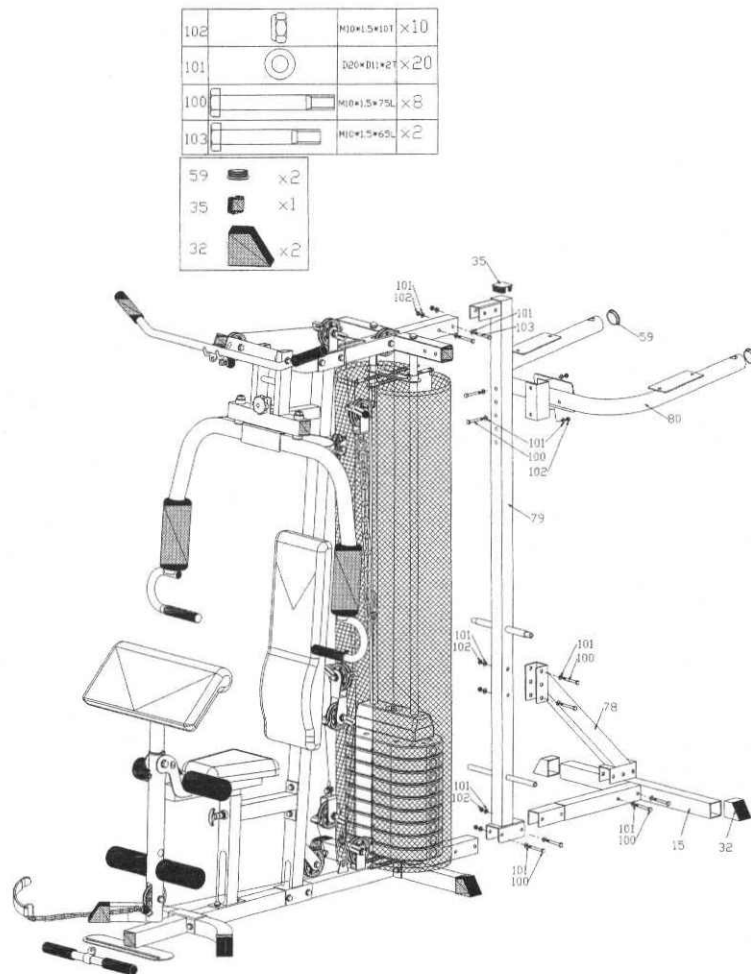



step 11



1. connect the rear vertical tube (79) with the base frame (1) and rear stabilizer (15) by using 2 bolt (100), 4 flat washer (101), 2 nut (102). Then connect the rear vertical tube with the upper beam by 2 bolt (103), 4 flat washer (101) and 2 nut (102).
2. attach the reinforce press tube (78) with rear vertical tube (79) and rear stabilizer (15) using 4 bolt (100), 6 flat washer (101), and 2 nut (102).
3. assembly the arm tube welding set (80) attach to the rear vertical tube (79) using 2 bolt (100), 4 flat washer (101), 2 nut (102).
4. insert 1 square plastic cap (35), 2 round cap (59) and 2 foot cap onto the tube.





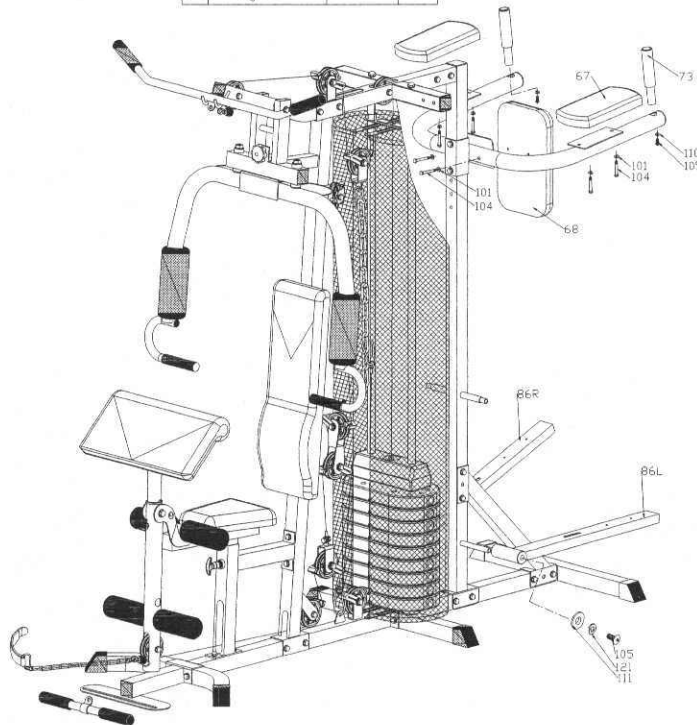

STEP 12

111		Ø28×Ø8.5×3T	×2
101		Ø20×Ø11×2T	×6
121		Ø15.4×Ø6.2×2T	×2
110		Ø19×Ø6.5×1.6T	×2
104		M10×1.5×70L	×6
105		M8×1.25×20	×4



1. fix the small back pad (68) onto the arm tube (80) using 2 bolt (104), 2 flat washer (101).
2. assembly 2 arm curl pad (67) with the arm tube by using 4 bolt (104), 4 flat washer (101)
3. fix the handlebar (73) with arm tube by means of 2 bolt(105), 2 flat washer (2).
4. attach 2 pedal support (86) by 1 bolt (105), 1 spring washer (121) and 1 flat washer (111).

STEP 13

111		D28*Ø8.5*3T	×2
118		M6*1*6T	×4
121		D15.4*Ø8.2*2T	×2
117		D14*Ø6.5*0.8T	×4
122		M6*1*55L	×4
105		M8*1.25*20	×2

83		×2
85		×2

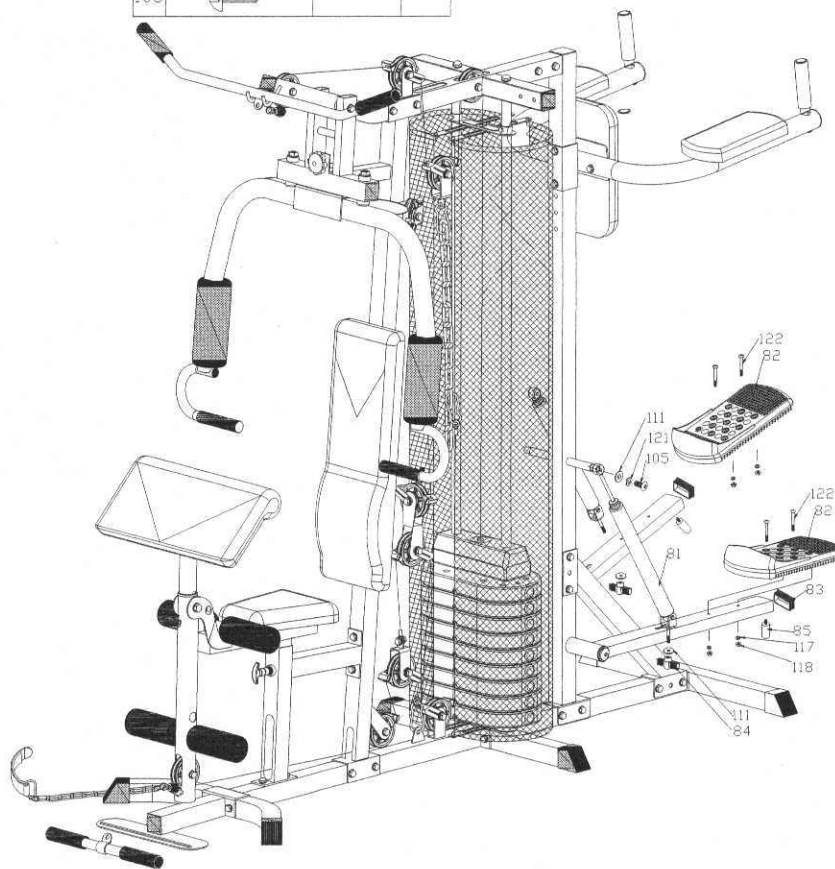

1. fix 2 pedal (82) onto the pedal support using 4 bolt (122), 4 flat washer (117) and 4 nut (118)
2. assembly the hydraulic cylinder (81) with the pedal support and rear vertical tube using 1 bolt (105), 1 spring washer (121), 1 flat washer (111) and 1 T knob (84), 1 flat washer (111).
3. cap the square cap (83) onto the pedal support.

STEP 14

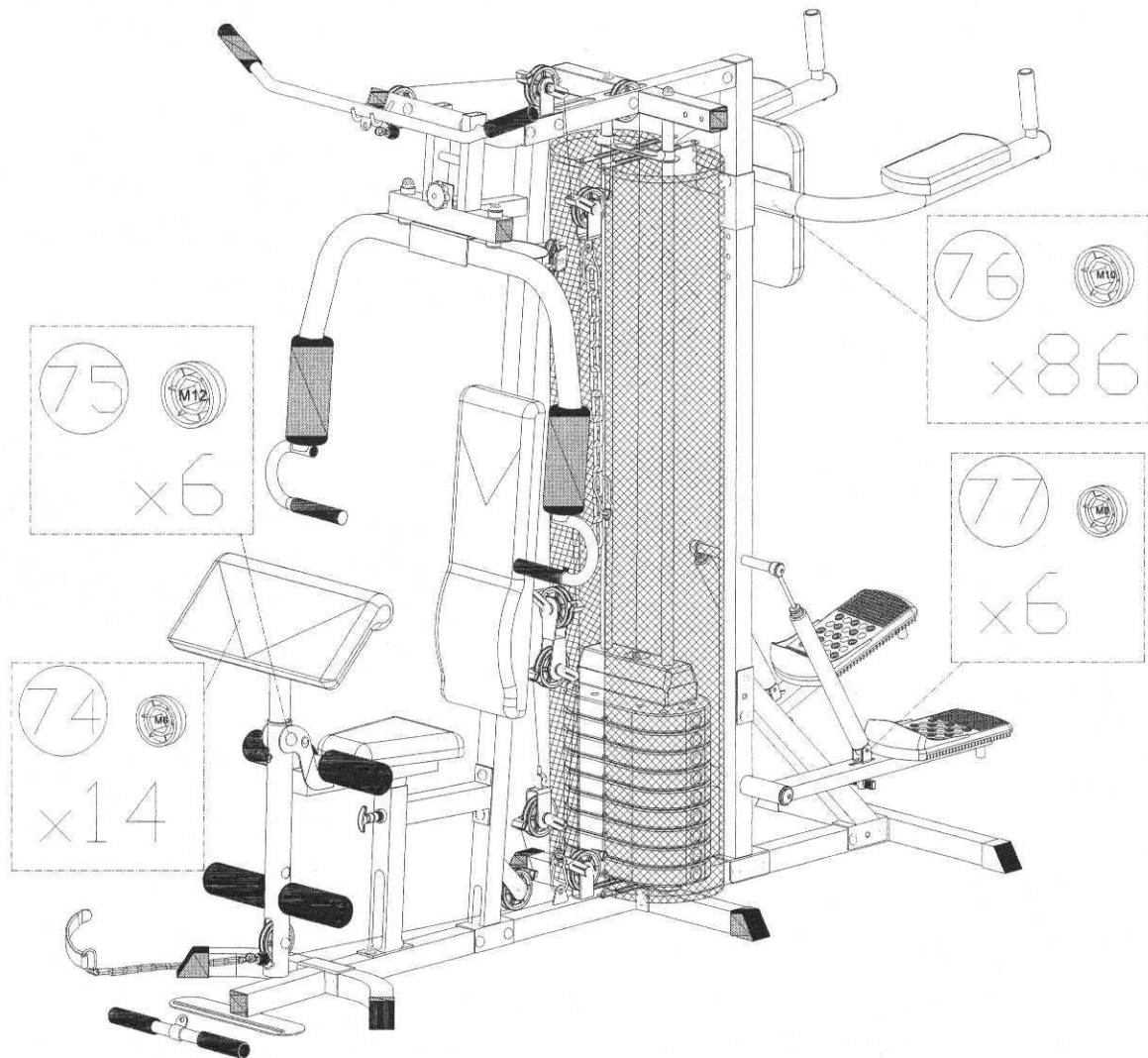

Please don't forget to fix the nut caps for the corresponding bolt.

