

Crosstrainer BASIC+

ITEM NO.: 1331N

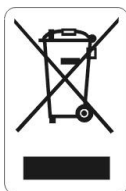
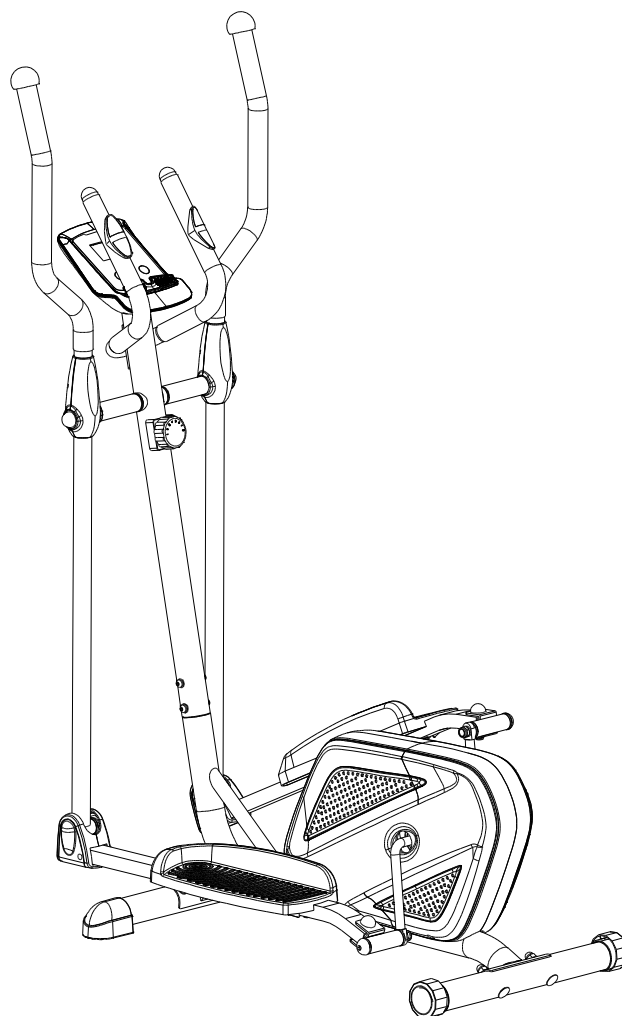

OWNER'S MANUAL

IMPORTANT: Read all instructions carefully before using this product. Retain this owner's manual for future reference. The specifications of this product may vary from this photo and are subject to change without prior notice.

TABLE OF CONTENTS

IMPORTANT SAFETY INSTRUCTIONS -----	2
PARTS LIST -----	3
TOOLS -----	5
HARDWARE LIST AND ASSEMBLY PART -----	6
EXPLODED VIEW -----	7
ASSEMBLY INSTRUCTIONS -----	8
HOW TO MOVE THE ELLIPTICAL TRAINER -----	21
OPERATING THE COMPUTER -----	22
ADJUSTMENTS -----	24
MAINTENANCE -----	25
TROUBLESHOOTING -----	25
WARM UP AND COOL DOWN ROUTINE -----	26

IMPORTANT SAFETY INSTRUCTIONS

Basic precautions should always be followed, including the following important safety instructions when using this equipment. Read all instructions before using this equipment.

1. Read all instructions and follow it carefully before using this equipment. Make sure the equipment is properly assembled and tightened before use.
2. Before exercise, in order to avoid injuring the muscle, warm-up exercises are recommended.
3. Please make sure all parts are not damaged and fixed well before use. This equipment should be placed on a flat surface when using. Using a mat or other covering material on the ground is recommended.
4. Please wear proper clothes and shoes when using this equipment; do not wear clothes that might catch any part of the equipment.
5. Do not attempt any maintenance or adjustments other than those described in this manual. Should any problems arise, discontinue use and consult your local dealer.
6. Be careful when step on or leave the pedal always hold the handlebars first. Make the pedal at your side at the lowest position, step on the pedal, and stride over the main frame then step on the other pedal. When using, please hold the handlebar by hands, make the pedals running smoothly by push or pull handlebars, then run the equipment regularly by cooperation of hands and feet. After exercise, please also make one pedal at the lowest position and leave your foot on the higher pedal first and then another.
7. Do not use the equipment outdoors.
8. This equipment is for household use only. It is not a commercial model.
9. Only one person at a time should use this equipment.
10. If you feel any chest pains, nausea, dizziness, or short of breath, you should stop exercising immediately and consult your physician before continuing.
11. Care should be taken in mounting or dismounting the equipment.
12. Do not allow children to use or play on the equipment. Keep children and pets away from the equipment while in use. This machine is designed for adults use only. The minimum free space required for safe operation is not less than two meters.
13. The maximum weight capacity for this product is 110 kg.

WARNING: Before beginning any exercise program consult your physician. This is especially important for people who are over 35 years old or who have pre-existing health problems. Read all instructions before using any fitness equipment. Do not operate this exercise equipment without properly fitted guards, as the moving parts can present a risk of serious injury if exposed.

CAUTION: Read all instructions carefully before operating this product. Retain this Owner's Manual for future reference.

PARTS LIST

No.	Description	Qty	No.	Description	Qty
001	Main Frame Ø50x2	1	021	Bearing 6000 2Z	2
002L	Left Foot Bar 40x25x1.5	1	022	Washer Ø40xØ24xδ2.5	1
002R	Right Foot Bar 40x25x1.5	1	023	U Shape Bracket	2
003L	Left Handrail Arm Ø32x1.5	1	024	Nylon Nut M8	2
003R	Right Handrail Arm Ø32x1.5	1	025	Washer Ø16xØ8x1.5	2
004L	Left Handrail Ø32x1.5	1	026	Hexagon Head Bolt M8x50	2
004R	Right Handrail Ø32x1.5	1	027	Nylon Nut M6	8
005	Front Post Ø50x1.5	1	028	Washer Ø6	7
006	Handlebar Ø28x1.5	1	029	Hexagon Head Bolt M6x40	6
007	Cross Recessed Pan Head Bolt M6x10	1	030	Tension Cable L=1600 mm	1
008	Cross Recessed Pan Head Tapping Screw ST2.9x10	2	031	Bolt Cap S13	2
009	Hexagon Socket Pan Head Cap Bolt M8x30	1	032	Cross Recessed Pan Head Tapping Screw ST4.2x25	7
010	Front Stabilizer Ø50x1.5x480	1	033L	Foot Bar Cover-A	2
011	Rear Stabilizer Ø50x1.5x480	1	033R	Foot Bar Cover-B	2
012	Carriage Bolt M10x57	4	034	Big Washer Ø20xØ8x2	2
013	Rear Stabilizer End Cap Ø50x1.5	2	035	Hexagon Socket Flat Head Cap Bolt Ø15.8x62.5	2
014	Big Curve Washer Ø10	4	036	Left Foot Pedal 395x150x65	1
015	Cap Nut M10	4	037	Right Foot Pedal 395x150x65	1
016L	Bolt for left U Shape Bracket Ø16x88.5xL23	1	038	Front Stabilizer End Cap Ø50	2
016R	Bolt for right U Shape Bracket Ø16x88.5xL23	1	039	Hexagon Head Bolt M6x48	2
017L	Left Nylon Nut 1/2"	1	040	Transport Wheel Ø23xØ6x32	2
017R	Right Nylon Nut 1/2"	1	041	Hexagon Socket Pan Head Cap Bolt M8x16	8
018	Wave Washer Ø28xØ17x0.3	2	042	Curve Washer Ø20xØ8	6
019	Powder Metal Bushing Ø29xØ16x14	8	043	Hexagon Head Bolt M10x18	2
020	Spring Washer Ø12	2	044	Spring Washer Ø18xØ10x2	2

PARTS LIST

No.	Description	Qty	No.	Description	Qty
045	Washer Ø28x5	2	065	Cross Recessed Pan Head Tapping Bolt M5x25	1
046	Powder Metal Bushing Ø33xØ29xØ16x14x4	4	066	Cross Recessed Pan Head Drilling Screw with Tapping Screw Thread ST4.2x25	4
047	Carriage Bolt M6x35	4	067	Extension Sensor Wire L=1100 mm	1
048	Curve Washer Ø6	4	068	Sensor with Wire L=950 mm	1
049	Bolt Cap S16	2	069	Cross Recessed Pan Head Drilling Screw with Tapping Screw Thread ST4.2x20	4
050	Cap Nut M6	4	070	Left Cover 544x345x86	1
051	Plastic Bushing Ø32xØ16x5xØ50	2	071	Right Cover 544x345x84	1
052L	Left Handrail Arm Cover-A	1	072	Bearing Cup Ø51.5	2
052R	Right Handrail Arm Cover-A	1	073	Ball Bearing	2
053L	Left Handrail Arm Cover-B	1	074	Bearing Nut I 15/16"	1
053R	Right Handrail Arm Cover-B	1	075	Bearing Nut II 7/8"	1
054	Tension Control Knob	1	076	Washer Ø34.5xØ23x2.5	1
055	Cross Recessed Pan Head Tapping Screw ST2.9x12	8	077	Hexagon Nut 7/8"	1
056	Computer	1	078	Belt Pulley with Crank Ø240	1
057	Cross Recessed Pan Head Bolt M5x12	4	079	Powder Metal Bushing Ø18xØ8x5	4
058	Hand Pulse Sensor L=750 mm	2	080	M10x1 Nut for Flywheel M10x1.25	2
059	Handrail Foam Grip Ø31xØ37x480	2	081	Flywheel Ø230x40x32	1
060	Spring Washer Ø8	6	082	Belt PJ330 J6	1
061	Handrail End Cap Ø32x1.5	2	083	Idle Wheel Bracket	1
062	Handlebar End Cap Ø28x1.5	2	084	Hexagon Socket Pan Head Cap Bolt M8x20	2
063	Cross Recessed Pan Head Tapping Screw ST4.2x20	2	085	Eyebolt M6x36	2
064	Curve Washer Ø20xØ5.2	1	086	Tension Bracket 31x31xØ1.0	2

PARTS LIST

No.	Description	Qty	No.	Description	Qty
087	Spring Washer Ø6	2	092	Big Washer Ø20xØ10x2	2
088	Nut M6	2	093	Curve Washer Ø16xØ8x1.5	2
089	Hexagon Socket Pan Head Cap Bolt M8x10	1	094	Washer Ø10.2xØ14xδ1.0	2
090	Handlebar Foam Grip Ø33xØ27x360	2	095	Rubber Cover	2
091	Cover Cap Ø40xØ25x10	2			

TOOLS



Allen Wrench S6
1 PC



Allen Wrench S8
1 PC

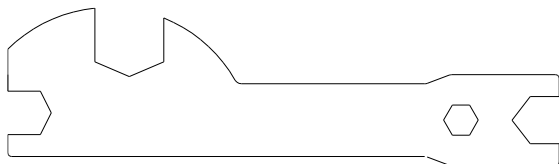

Multi Hex Tool
S10, S13, S17, S19
1 PC

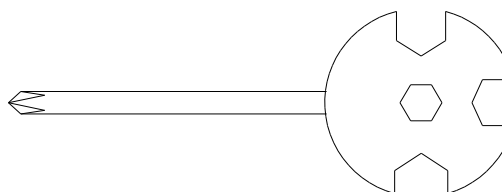

Multi Hex Tool with Phillips Screwdriver
S10, S13, S14, S15
1 PC

HARDWARE LIST AND ASSEMBLY PART

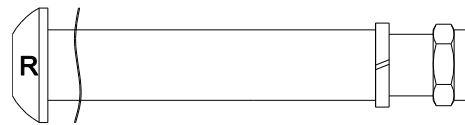
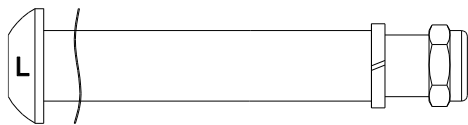

(16L) Bolt for left U Shape Bracket 1 PC
 (17L) Left Nylon Nut 1 PC
 (18) Wave Washer 1 PC
 (20) Spring Washer 1 PC

(16R) Bolt for right U Shape Bracket 1 PC
 (17R) Right Nylon Nut 1 PC
 (18) Wave Washer 1 PC
 (20) Spring Washer 1 PC

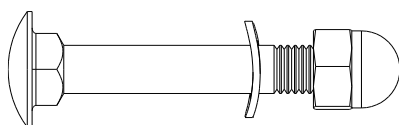

(12) Carriage Bolt 4 PCS
 (14) Big Curve Washer 4 PCS
 (15) Cap Nut 4 PCS



(27) Nylon Nut 6 PCS
 (28) Washer 6 PCS
 (29) Hexagon Head Bolt 6 PCS

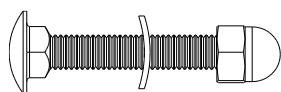

(47) Carriage Bolt 4 PCS
 (48) Curve Washer 4 PCS
 (50) Cap Nut 4 PCS



(31) Bolt Cap
 2 PCS

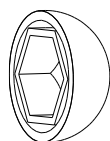

(49) Bolt Cap
 2 PCS

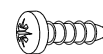

(55) Cross Recessed Pan
 Head Tapping Screw
 8 PCS

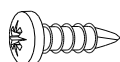

(69) Cross Recessed Pan
 Head Drilling Screw with
 Tapping Screw Thread
 4 PCS

EXPLODED VIEW

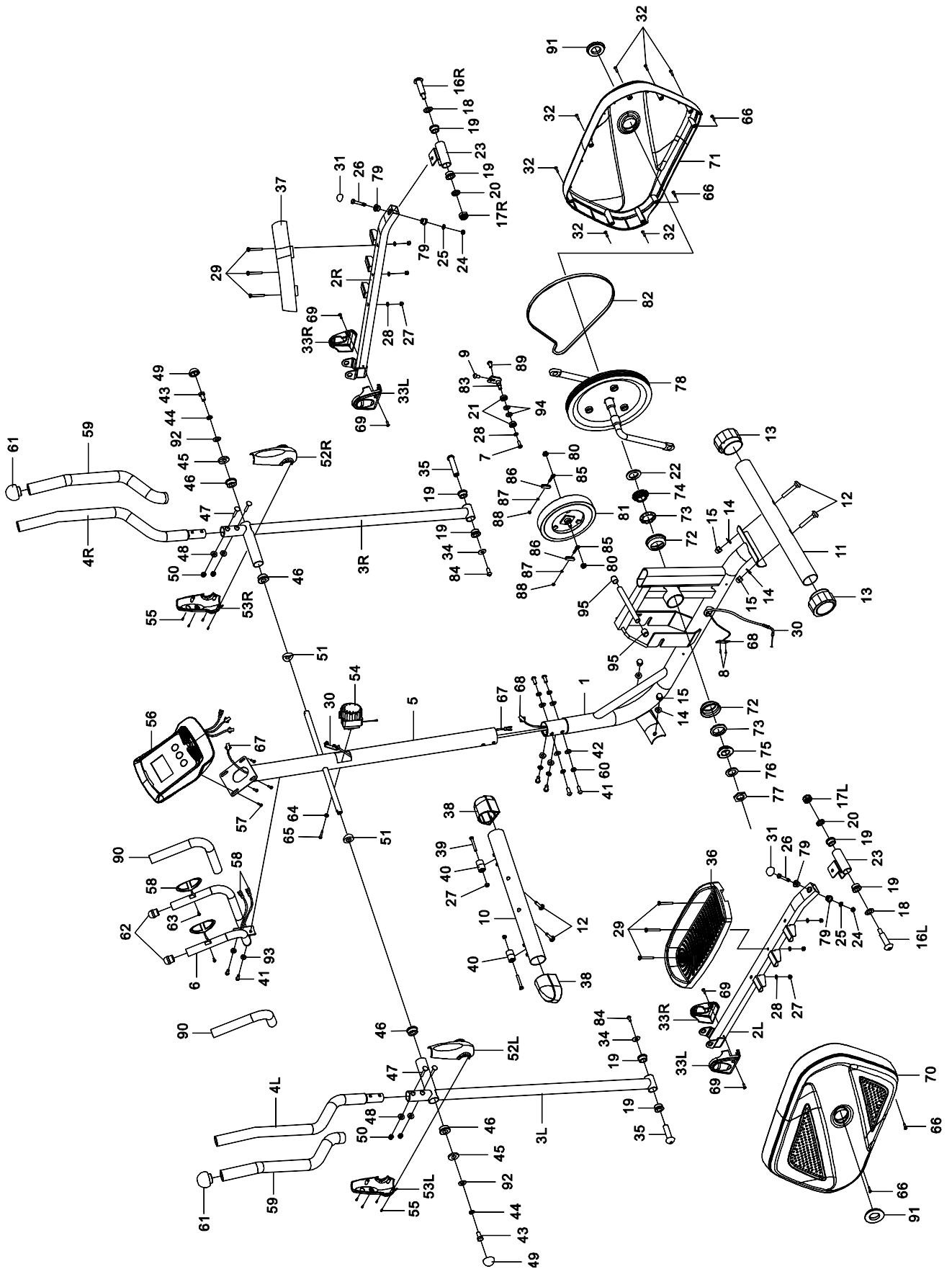

ASSEMBLY INSTRUCTIONS

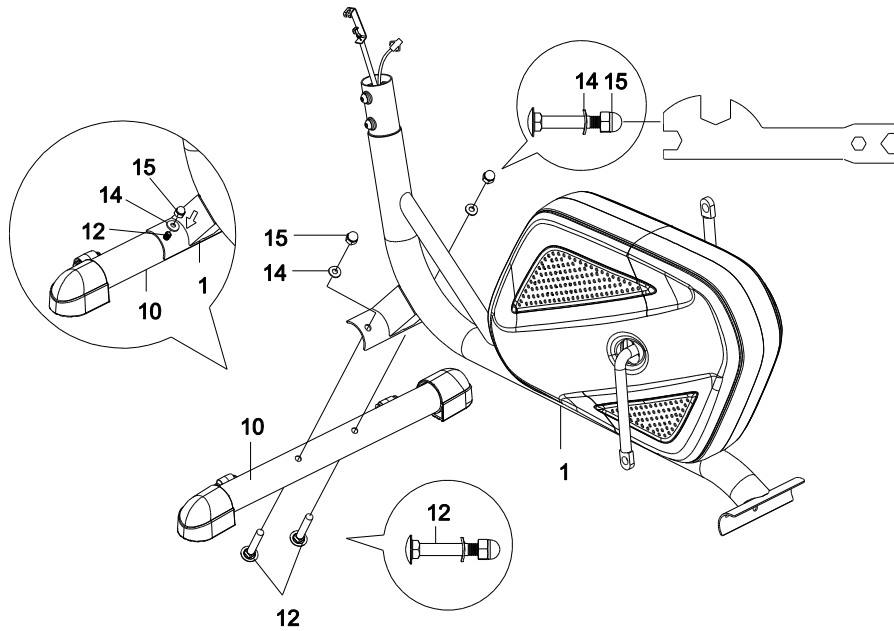

STEP 1

Position the Front Stabilizer (10) in front of the Main Frame (1) and align bolt holes. Attach the Front Stabilizer (10) onto the front curve of the Main Frame (1) with two Carriage Bolts (12), two Big Curve Washers (14), and two Cap Nuts (15). Tighten cap nuts with the Multi Hex Tool provided.

Hardware:

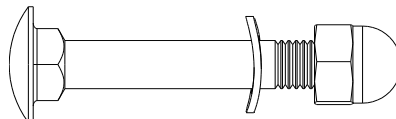

- | | |
|-----------------------|-------|
| (12) Carriage Bolt | 2 PCS |
| (14) Big Curve Washer | 2 PCS |
| (15) Cap Nut | 2 PCS |

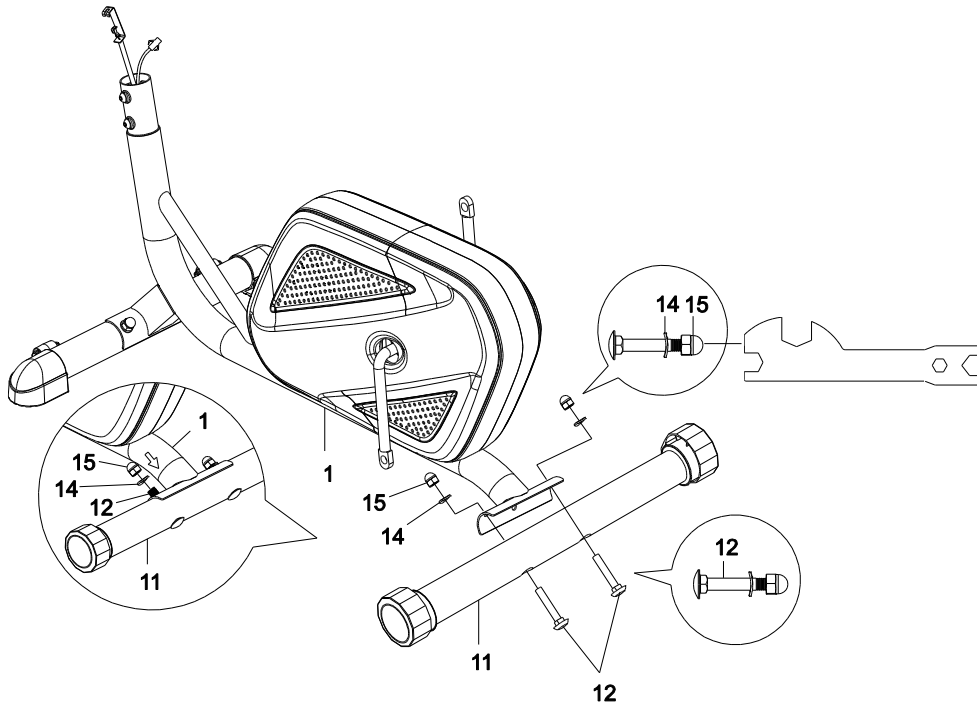

STEP 2

Position the Rear Stabilizer (11) behind the Main Frame (1) and align bolt holes. Attach the Rear Stabilizer (11) onto the rear curve of the Main Frame (1) with two Carriage Bolts (12), two Big Curve Washers (14), and two Cap Nuts (15). Tighten cap nuts with the Multi Hex Tool provided.

Hardware:

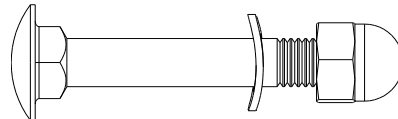

- | | |
|-----------------------|-------|
| (12) Carriage Bolt | 2 PCS |
| (14) Big Curve Washer | 2 PCS |
| (15) Cap Nut | 2 PCS |

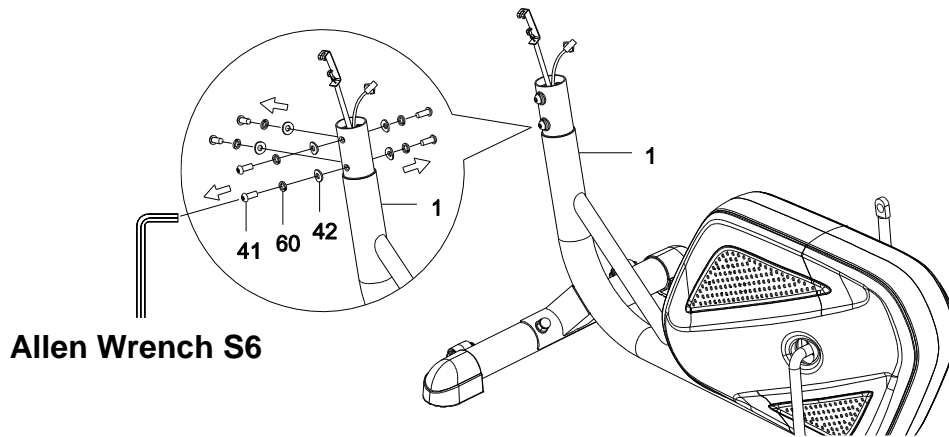

STEP 3

Remove six Hexagon Socket Pan Head Cap Bolts (41), six Spring Washers (60), and six Curve Washers (42) from the Main Frame (1). Remove bolts with the S6 Allen Wrench provided.

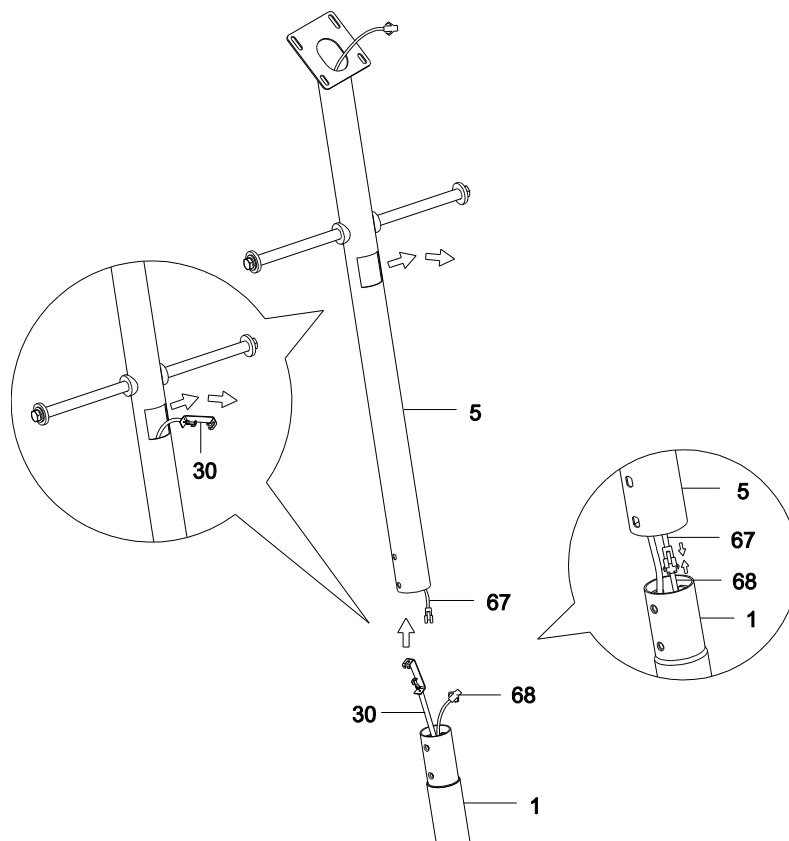

STEP 4

It is recommended to have a second person assist with this step. One person should hold the Front Post (5) in place while the other person to connect the wires.

Insert the Tension Cable (30) through into the bottom hole of the Front Post (5) and pull it out from the square hole of the Front Post (5).

Connect the Sensor Wire (68) from the Main Frame (1) to the Extension Sensor Wire (67) from the Front Post (5).

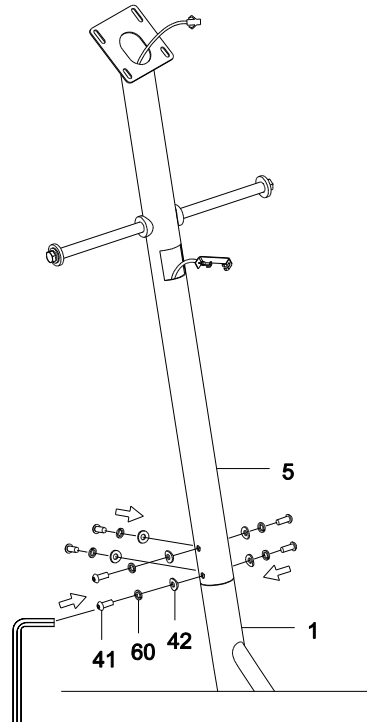

Allen Wrench S6

STEP 5

Insert the Front Post (5) onto the tube of the Main Frame (1) and secure with six Hexagon Socket Pan Head Cap Bolts (41), six Spring Washers (60), and six Curve Washers (42) that were removed. Tighten bolts with the S6 Allen Wrench provided.

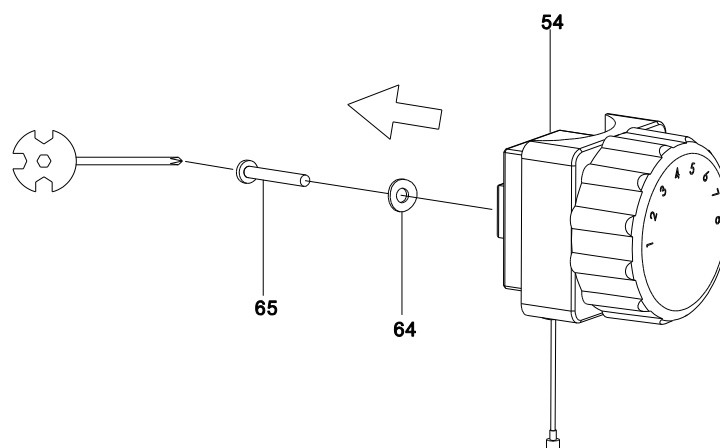

STEP 6

Remove one Cross Recessed Pan Head Tapping Bolt (65) and one Curve Washer (64) from the Tension Control Knob (54). Remove bolt with the Multi Hex Tool with Phillips Screwdriver provided.

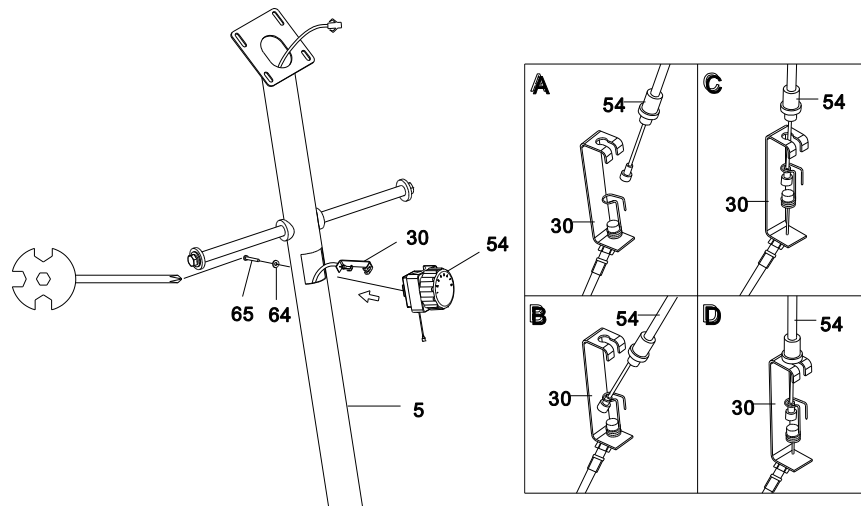

STEP 7

Put the cable end of resistance cable of Tension Control Knob (54) into the cable lock of Tension Cable (30), see Figure A.

Pull the resistance cable of Tension Control Knob (54) up and force it into the slot of metal bracket of Tension Cable (30), see Figure B.

Insert the metal fitting on the resistance cable of Tension Control Knob (54) into the hole at the end of the slot in the metal bracket of Tension Cable (30), see Figure C.

Connect the resistance cable of Tension Control Knob (54) to Tension Cable (30) complete, see Figure D.

Attach the Tension Control Knob (54) onto the Front Post (5) with one Cross Recessed Pan Head Tapping Bolt (65) and one Curve Washer (64) that were removed. Tighten bolt with the Multi Hex Tool with Phillips Screwdriver provided.

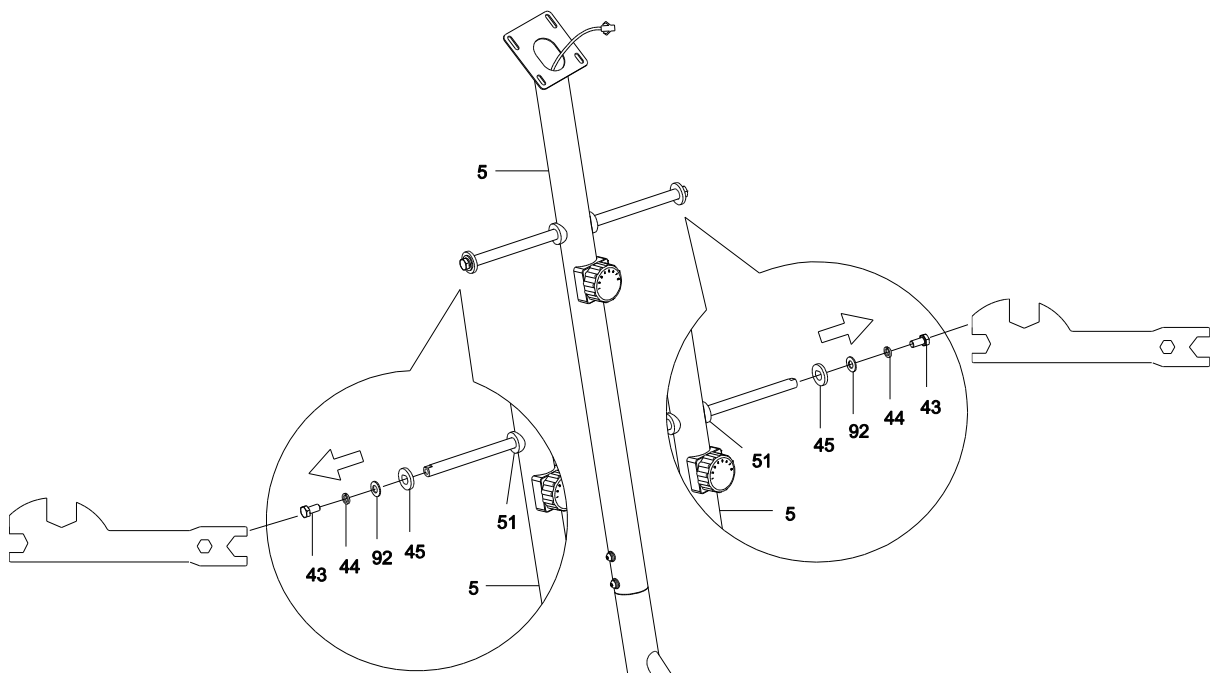

STEP 8

Remove two Hexagon Head Bolts (43), two Spring Washers (44), two Big Washers (92), and two Washers (45) from the left and right horizontal axes of the Front Post (5). Remove bolts with the Multi Hex Tool provided.

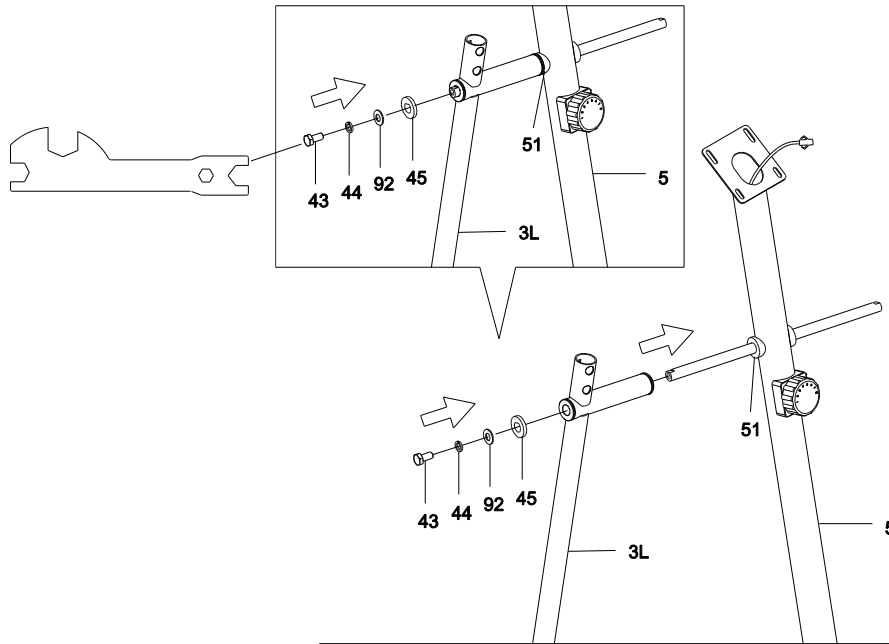

STEP 9

Attach the Left Handrail Arm (3L) onto the left horizontal axis of the Front Post (5) with one Hexagon Head Bolt (43), one Spring Washer (44), one Big Washer (92), and one Washer (45) that were removed. Tighten bolt with the Multi Hex Tool provided.

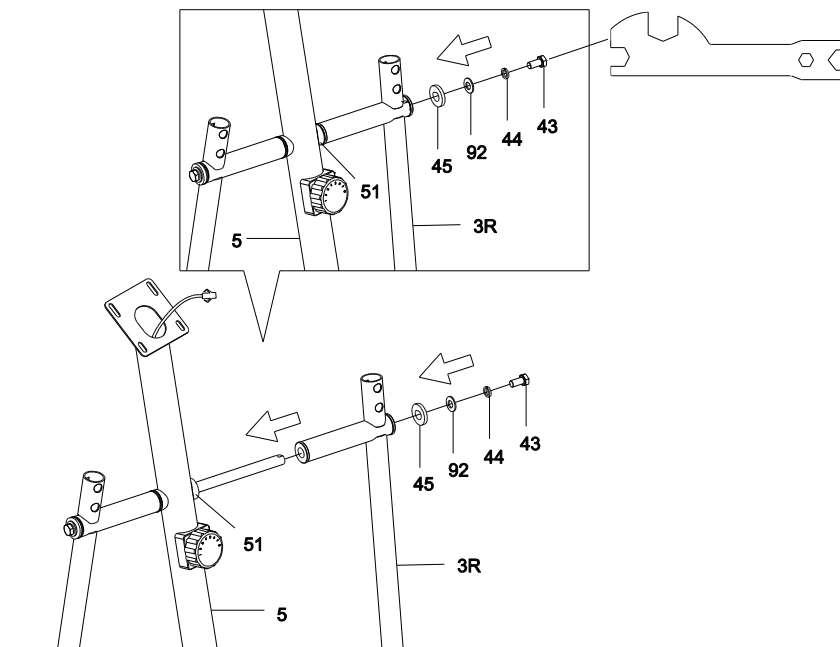

STEP 10

Attach the Right Handrail Arm (3R) onto the right horizontal axis of the Front Post (5) with one Hexagon Head Bolt (43), one Spring Washer (44), one Big Washer (92), and one Washer (45) that were removed. Tighten bolt with the Multi Hex Tool provided.

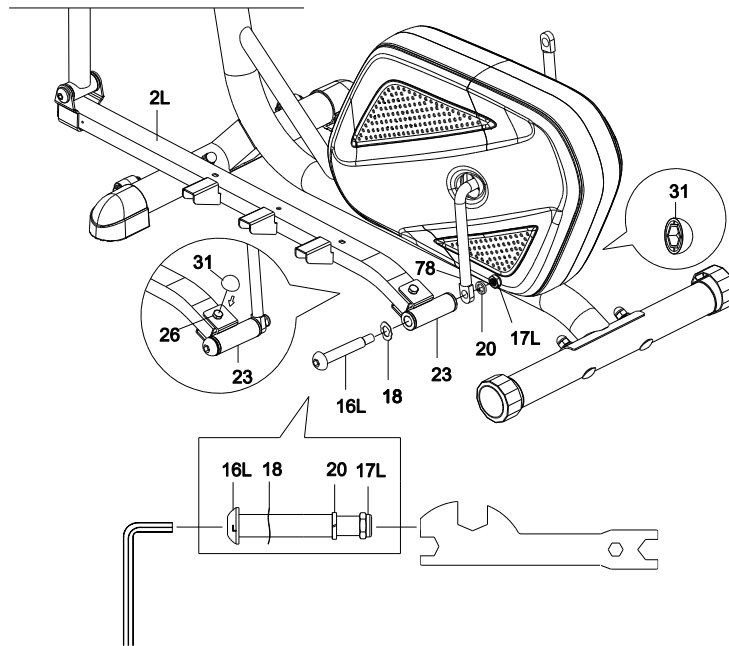

Allen Wrench S8

STEP 11

Attach the left U Shape Bracket (23) to the left Crank (78) with one Bolt for left U Shape Bracket (16L), one Wave Washer (18), one Spring Washer (20), and one Left Nylon Nut (17L). Tighten bolt and nylon nut with the S8 Allen Wrench and Multi Hex Tool provided. Install a Bolt Cap (31) onto the Hexagon Head Bolt (26).

NOTE: Bolt for left U Shape Bracket (16L) is marked “L” for Left.

Hardware & Assembly Part:

Bolt is marked “L” for Left.

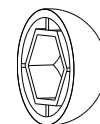
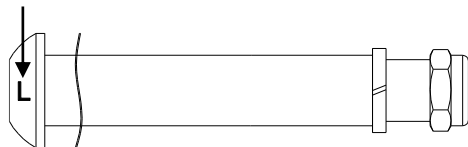

- (16L) Bolt for left U Shape Bracket 1 PC
- (17L) Left Nylon Nut 1 PC
- (18) Wave Washer 1 PC
- (20) Spring Washer 1 PC

- (31) Bolt Cap 1 PC

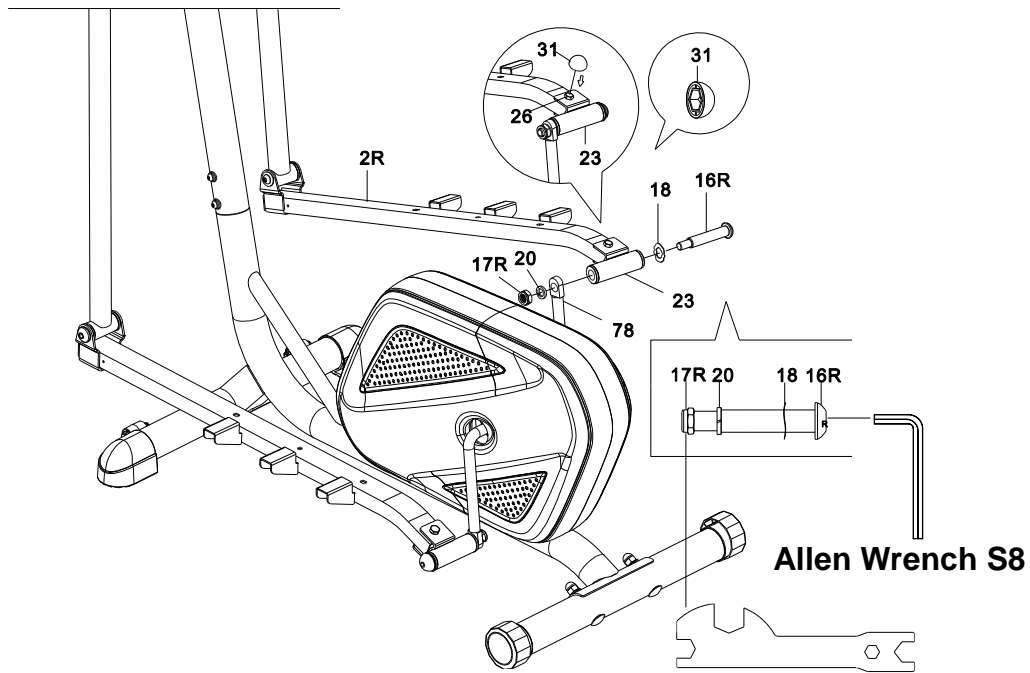

STEP 12

Attach the left U Shape Bracket (23) to the right Crank (78) with one Bolt for right U Shape Bracket (16R), one Wave Washer (18), one Spring Washer (20), and one Right Nylon Nut (17R). Tighten bolt and nylon nut with the S8 Allen Wrench and Multi Hex Tool provided. Install a Bolt Cap (31) onto the Hexagon Head Bolt (26).

NOTE: Bolt for right U Shape Bracket (16R) is marked “R” for Right.

Hardware & Assembly Part:

Bolt is marked “R” for Right.

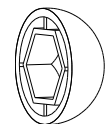
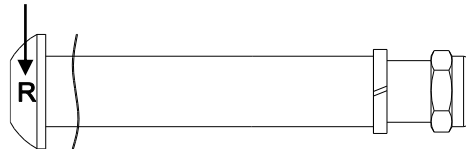

(16R) Bolt for right U Shape Bracket
1 PC

(31) Bolt Cap
1 PC

(17R) Right Nylon Nut 1 PC

(18) Wave Washer 1 PC

(20) Spring Washer 1 PC

Hardware:

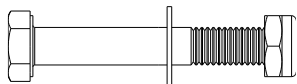

- (27) Nylon Nut 6 PCS
- (28) Washer 6 PCS
- (29) Hexagon Head Bolt 6 PCS

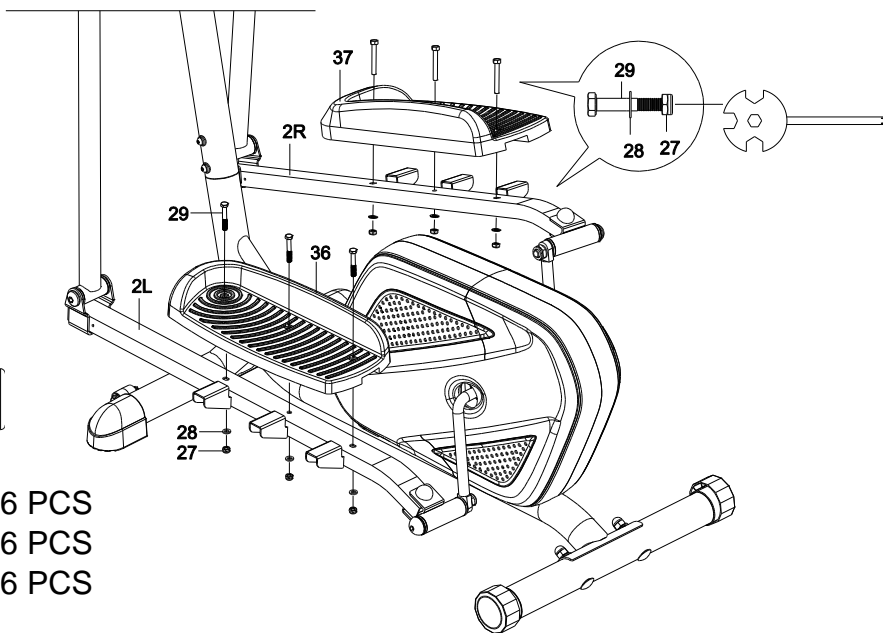

STEP 13

Attach the Left Foot Pedal (36) onto the Left Foot Bar (2L) with three Hexagon Head Bolts (29), three Washers (28), and three Nylon Nuts (27). Tighten the nylon nuts with the Multi Hex Tool with Phillips Screwdriver provided.

Attach the Right Foot Pedal (37) onto the Right Foot Bar (2R) with three Hexagon Head Bolts (29), three Washers (28), and three Nylon Nuts (27). Tighten the nylon nuts with the Multi Hex Tool with Phillips Screwdriver provided.

Hardware:

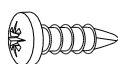

- (69) Cross Recessed Pan Head Drilling Screw with Tapping Screw Thread 4 PCS

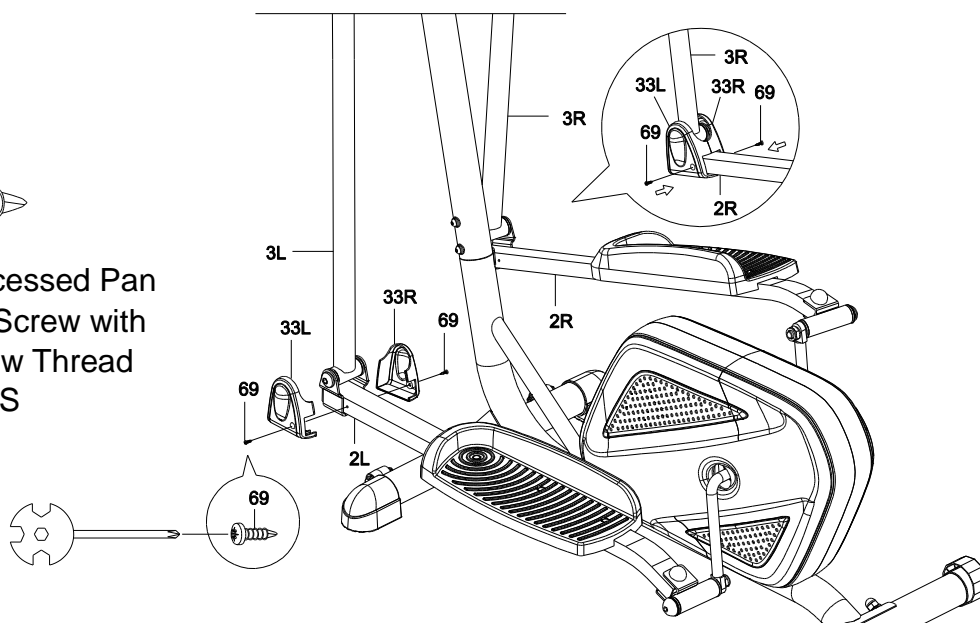

STEP 14

Attach two Foot Bar Covers-A (33L) and two Foot Bar Covers-B (33R) onto the front end of the Left and Right Foot Bars (2L, 2R) with four Cross Recessed Pan Head Drilling Screws with Tapping Screw Thread (69). Tighten screws with the Multi Hex Tool with Phillips Screwdriver provided.

Hardware:

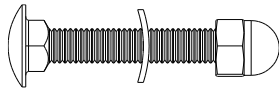

- (47) Carriage Bolt 4 PCS
- (48) Curve Washer 4 PCS
- (50) Cap Nut 4 PCS

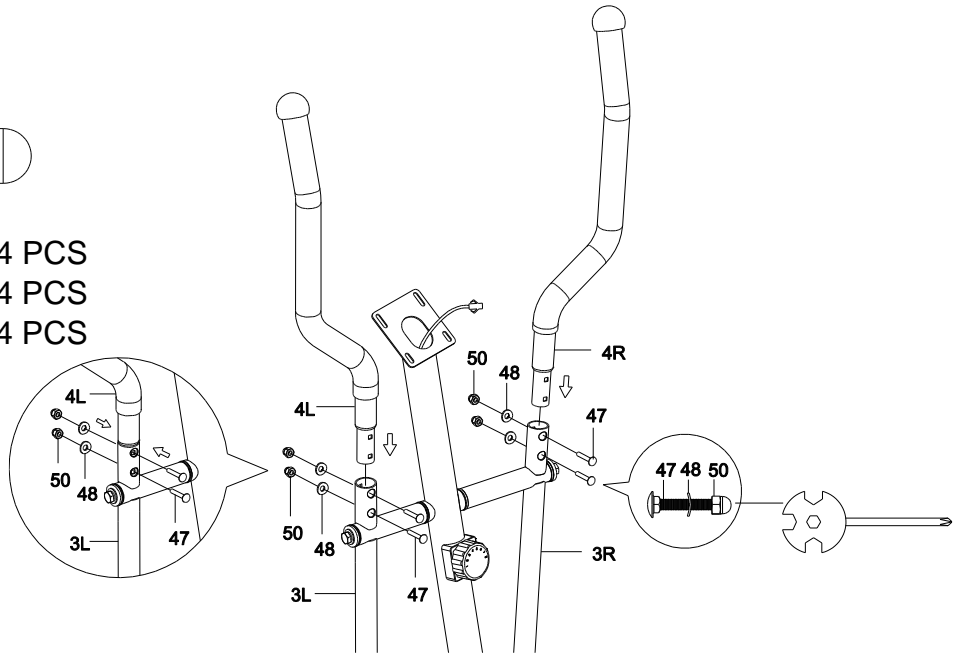

STEP 15

Attach both Right and Left Handrails (4R, 4L) into the top ends of both Right and Left Handrail Arms (3R, 3L) with four Carriage Bolts (47), four Curve Washers (48), and four Cap Nuts (50). Tighten cap nuts with the Multi Hex Tool Phillips Screwdriver provided.

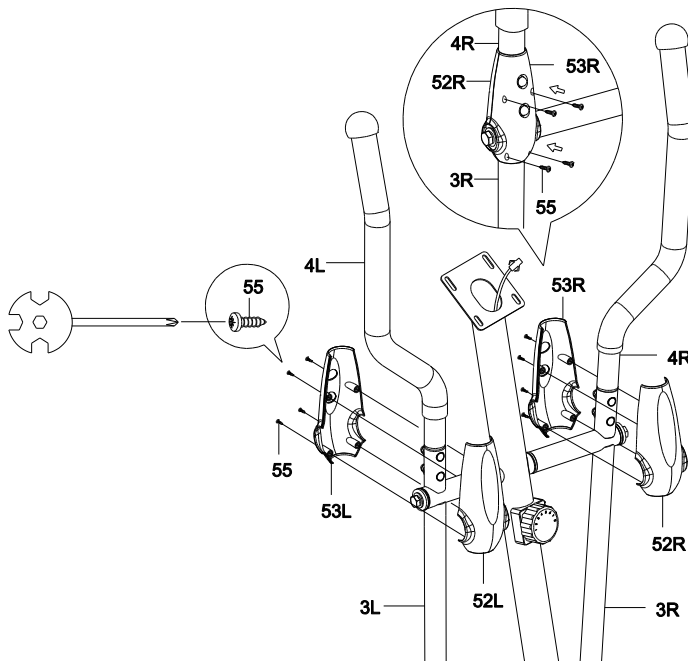

Hardware:



- (55) Cross Recessed Pan Head Tapping Screw 8 PCS

STEP 16

Attach the Left Handrail Arm Cover-A (52L) and Left Handrail Arm Cover-B (53L) onto the Left Handrail Arm (3L) with four Cross Recessed Pan Head Tapping Screws (55). Tighten screws with the Multi Hex Tool with Phillips Screwdriver provided.

Attach the Right Handrail Arm Cover-A (52R) and Right Handrail Arm Cover-B (53R) onto The Right Handrail Arm (3R) with four Cross Recessed Pan Head Tapping Screws (55). Tighten screws with the Multi Hex Tool with Phillips Screwdriver provided.

Assembly Part:

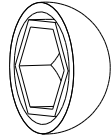

(49) Bolt Cap
2 PCS

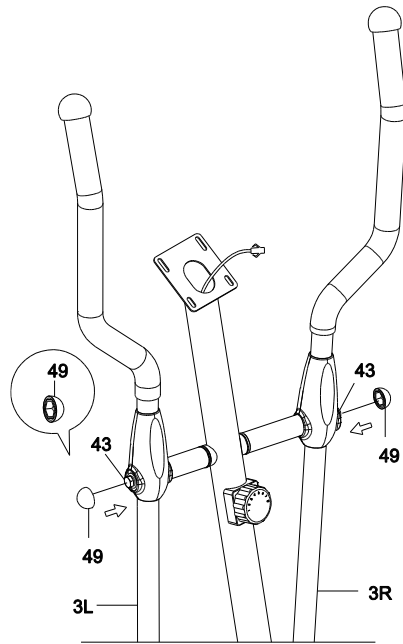

STEP 17

Install a two Bolt Caps (49) onto two Hexagon Head Bolts (43).

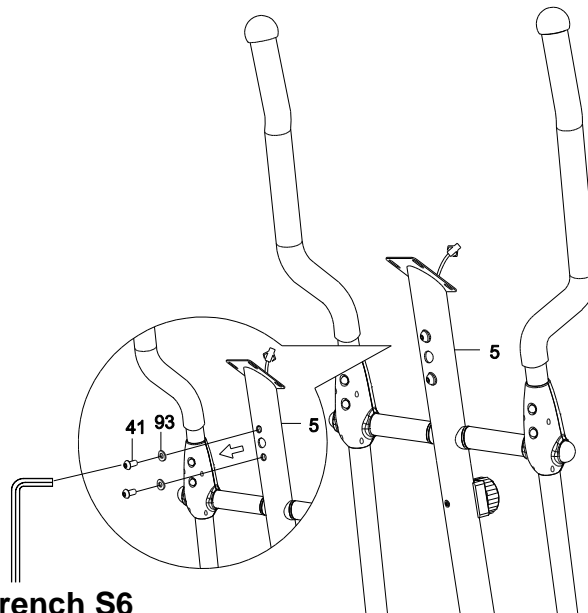

Allen Wrench S6

STEP 18

Remove two Hexagon Socket Pan Head Cap Bolts (41) and two Curve Washers (93) from the Front Post (5). Remove bolts with the S6 Allen Wrench provided.

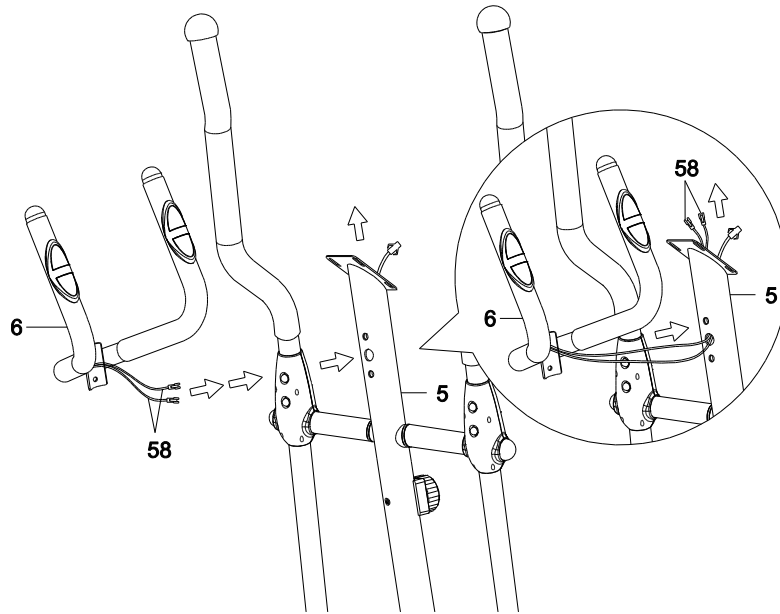

STEP 19

Insert the Hand Pulse Sensor Wires (58) from the Handlebar (6) into the hole on the Front Post (5) and then pull them out from the top end of the Front Post (5).

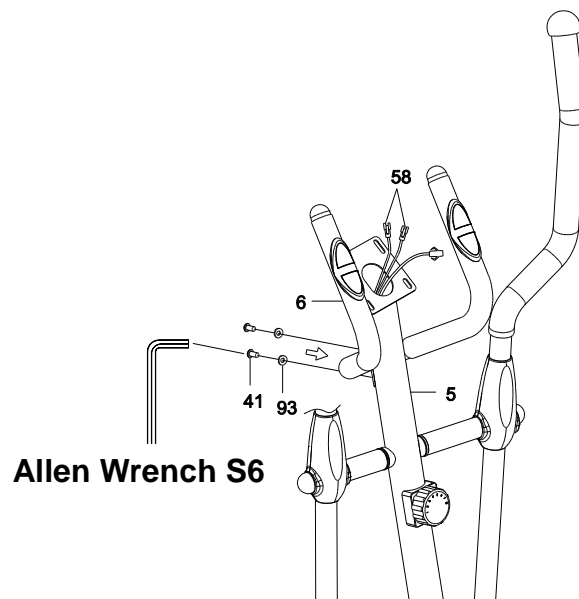

STEP 20

Attach the Handlebar (6) onto the Front Post (5) with two Hexagon Socket Pan Head Cap Bolts (41) and two Curve Washers (93) that were removed. Tighten bolts with the S6 Allen Wrench provided.

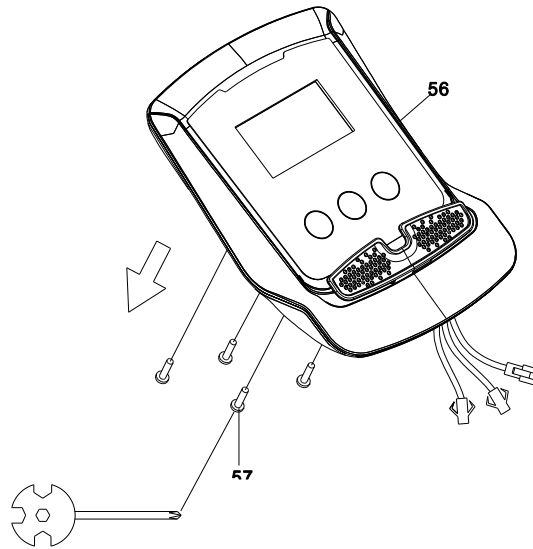

STEP 21

Remove four Cross Recessed Pan Head Bolts (57) from the Computer (56). Remove bolts with the Multi Hex Tool with Phillips Screwdriver provided.

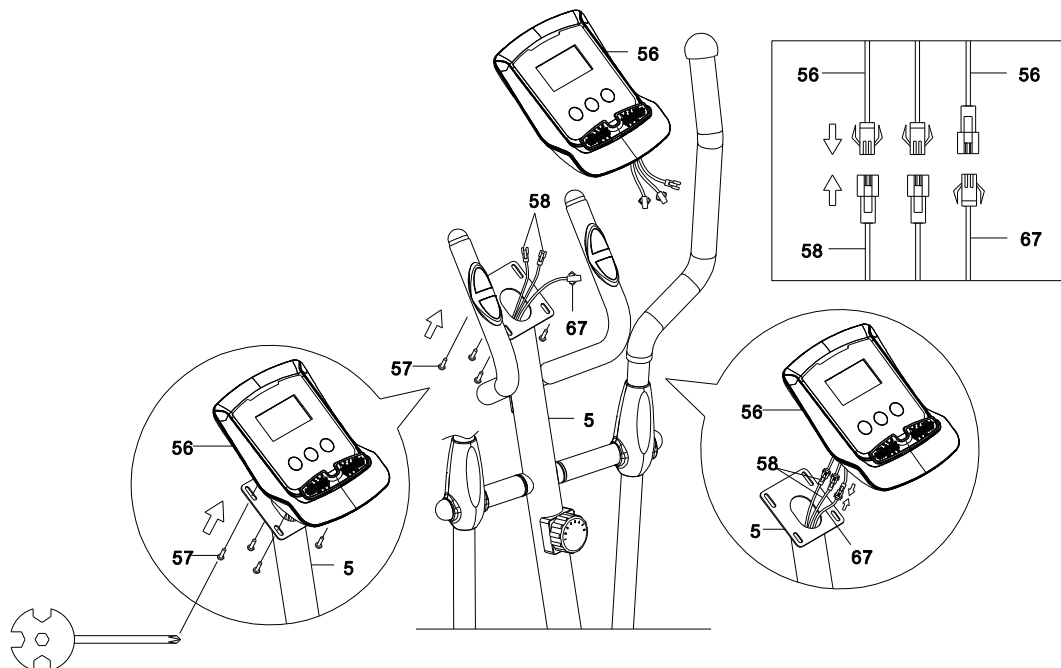

STEP 22

It is recommended to have a second person assist with this step. One person should hold the Computer (56) in place while the other person to connect the wires. Connect the Hand Pulse Sensor Wires (58) and Extension Sensor Wire (67) to the wires that come from the Computer (56). Tuck wires into the Front Post (5). Attach the Computer (56) onto the top end of the Front Post (5) with four Cross Recessed Pan Head Bolts (57) that were removed. Tighten bolts with the Multi Hex Tool with Phillips Screwdriver provided.

HOW TO MOVE THE ELLIPTICAL TRAINER

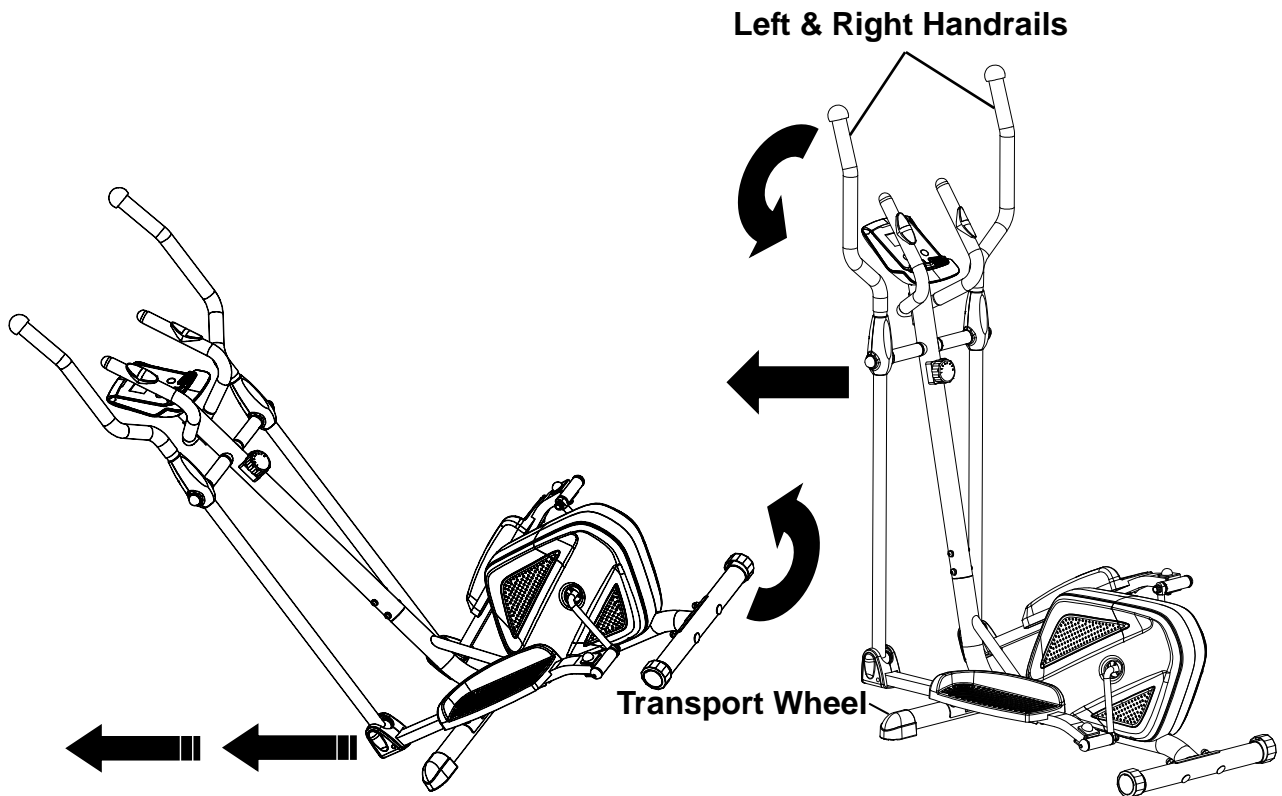

This elliptical trainer has a pair of Transport Wheels built into the front stabilizer and can be carefully tilted onto its Transport Wheels for easy moving and storage. Stand in front of the unit and grasp the Left and Right Handrails with both hands, then push or pull both handrails to make them parallel. Next, carefully push the elliptical trainer down until it rolls freely on the Transport Wheels.

CAUTION: It is suggested you always use the aid of a second person when moving the elliptical trainer.

OPERATING THE COMPUTER



USING YOUR COMPUTER

The computer can be activated by pressing one of the three buttons or by pedaling. If you leave the equipment idle for 4 minutes, the power will turn off automatically.

BUTTON FUNCTIONS:

MODE: Press the MODE button to select the functions of the computer.

Press and hold the MODE button for 3 seconds to reset all data values to zero except the TOTAL data values.

SET: Press the SET button to set data values of TMR (TIMER), DST (DISTANCE), or CAL (CALORIES) for target pre-setting.

RESET: Press the RESET button to reset data values of TMR (TIMER), DST (DISTANCE), or CAL (CALORIES) to zero.

Press and hold the RESET button for 3 seconds to reset all data values to zero except the TOTAL data values.

COMPUTER FUNCTIONS:

SCAN: Press the MODE button until the screen displays SCAN, the computer will automatically scan each function in sequence with change every 6 seconds.

TMR (TIMER): Displays your elapsed workout time in minutes and seconds. You may also pre-set target time in STOP mode before training. To set TIMER press the MODE button until the screen displays TMR. Press the SET button to change the time, each time you press the SET button time should change by 1 minute. Press the RESET button to clear the target time to zero. The pre-set target time range is from 0:00 to 99:00 minutes. Once you pre-set target time and then start to exercise, time starts counting down from pre-set target time to 0:00 per 1 second backward. When the pre-set target time counts down to 0:00, time will start to count up immediately and the computer will begin beeping to remind you.

SPD (SPEED): Displays the current training speed.

DST (DISTANCE): Displays the cumulative distance travelled during workout. You may also pre-set target distance in STOP mode before training. To set DISTANCE press the MODE button until the screen displays DST. Press the SET button to change the distance, each time you press the SET button distance should change by 0.1 km. Press the RESET button to clear the target distance to zero. The pre-set target distance range is from 0.0 to 99.90 km. Once you pre-set target distance and then start to exercise, distance starts counting down from pre-set target distance to 0.0. When the pre-set target distance counts down to 0.0, distance will start to count up immediately and the computer will begin beeping to remind you.

CAL (CALORIES): Displays approximate amount of calories burned during workout. You may also pre-set target calories in STOP mode before training. To set CALORIES press the MODE button until the screen displays CAL. Press the SET button to change the calories, each time you press the SET button calories should change by 1.0 calorie. Press the RESET button to clear the target calories to zero. The pre-set target calories range is from 0.0 to 999.0 calories. Once you pre-set target calories and then start to exercise, calories start counting down from pre-set target calories to 0.0. When the pre-set target calories count down to 0.0, calories will start to count up immediately and the computer will begin beeping to remind you. (This data is a rough guide for comparison of different exercise sessions and should not be used in medical treatment).

TOTAL: Displays the total accumulative distance travelled. The TOTAL data values can not be reset to zero by pressing and holding the MODE or RESET button for 3 seconds. If you take out the batteries from the computer, the TOTAL data values will reset to zero.

PULSE: Displays your current heart rate figures after you grip the handlebar pulse sensors with both your hands during exercise. To ensure the pulse readout is more precise, please always hold on to the handlebar pulse sensors with two hands instead of just with one hand only when you try to test your heart rate figures.

HOW TO INSTALL THE BATTERIES:

1. Remove the battery cover on the back of the computer.
2. Place two size AA batteries into the battery housing.
3. Insure batteries are correctly positioned and battery springs are in proper contact with batteries.
4. Re-install the battery cover.
5. If the display is illegible or only partial segment appears, remove batteries and wait 15 seconds before reinstalling.

ADJUSTMENTS

Adjusting the Tension Control Knob

To increase the tension, turn the tension control knob
In a clockwise direction.

To decrease the tension, turn the tension control knob
in a counterclockwise direction.

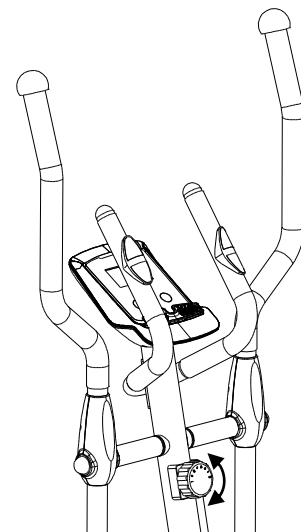

Tension Control Knob

Adjusting the Rear Stabilizer End Cap

Turn the rear stabilizer end cap on the rear stabilizer as
needed to level the elliptical trainer.

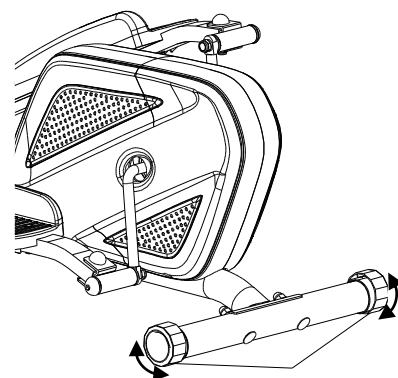

Rear Stabilizer End Cap

MAINTENANCE

Cleaning

The elliptical trainer can be cleaned with a soft clean damp cloth. Do not use abrasives or solvents on plastic parts. Please wipe your perspiration off the elliptical trainer after each use. Be careful not to get excessive moisture on the computer display panel as this might cause an electrical hazard or electronics to fail.

Please keep the elliptical trainer, especially the computer console out of direct sunlight to prevent screen damage.

Please inspect all assembly bolts, nuts, screws, and pedals on the machine for proper tightness every week.

Storage

Store the elliptical trainer in a clean and dry environment away from children.

TROUBLESHOOTING

PROBLEM: The elliptical trainer wobbles when in use.

SOLUTION: Turn the rear stabilizer end cap on the rear stabilizer as needed to level the elliptical trainer.

PROBLEM: There is no display on the computer console.

SOLUTION: Remove the computer console and verify the wires that come from the computer console are properly connected to the wires that come from the front post.

SOLUTION: Check if the batteries are correctly positioned and battery springs are in proper contact with batteries.

SOLUTION: The batteries in the computer console may be dead. Replace with new batteries.

PROBLEM: There is no heart rate reading or heart rate reading is erratic / inconsistent.

SOLUTION: Make sure that the wire connections for the hand pulse sensors are secure.

SOLUTION: To ensure the pulse readout is more precise, please always hold on to the handlebar grip sensors with both hands instead of just with one hand when you try to test your heart rate figures.

SOLUTION: Avoid gripping the hand pulse sensors too tight. Try to maintain moderate pressure while holding onto the hand pulse sensors.

PROBLEM: The elliptical trainer makes a squeaking noise when in use.

SOLUTION: The bolts may be loose on the elliptical trainer. Please inspect all of the bolts and tighten any loose bolts.

If the above troubleshooting section does not fix the problem, discontinue use the elliptical trainer.

PLEASE CONTACT YOUR LOCAL DEALER FOR SUPPORT.

WARM UP AND COOL DOWN ROUTINE

The **WARM-UP** is an important part of any workout. The purpose of warming up is to prepare your body for exercise and to minimize injuries. Warm up for two to five minutes before aerobic exercising. It should begin every session to prepare your body for more strenuous exercise by heating up and stretching your muscles, increasing your circulation and pulse rate, and delivering more oxygen to your muscles.

COOL DOWN at the end of your workout, repeat these exercises to reduce soreness in tired muscles. The purpose of cooling down is to return the body to its resting state at the end of each exercise session. A proper cool-down slowly lowers your heart rate and allows blood to return to the heart.

HEAD ROLLS

Rotate your head to the right for one count, you should feel a stretching sensation up the left side of your neck. Then rotate your head back for one count, stretching your chin to the ceiling and letting your mouth open. Rotate your head to the left for one count, then drop your head to your chest for one count.

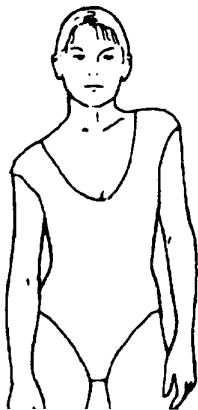
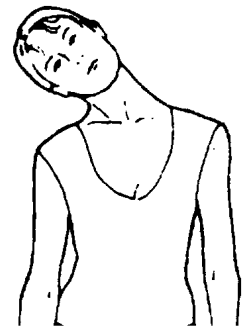

SHOULDER LIFTS

Lift your right shoulder toward your ear for one count. Then lift your left shoulder up for one count as you lower your right shoulder.

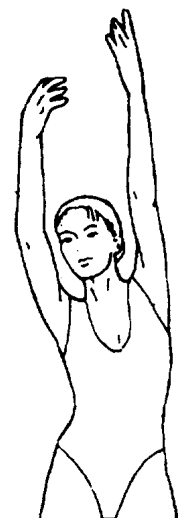

SIDE STRETCHES

Open your arms to the side and lift them until they are over your head. Reach your right arm as far toward the ceiling as you can for one count. Repeat this action with your left arm.



QUADRICEPS STRETCH

With one hand against a wall for balance, reach behind you and pull your right foot up. Bring your heel as close to your buttocks as possible. Hold for 15 counts and repeat with left foot.

INNER THIGH STRETCH

Sit with the soles of your feet together and your knees pointing outward. Pull your feet as close to your groin as possible. Gently push your knees toward the floor. Hold for 15 counts.

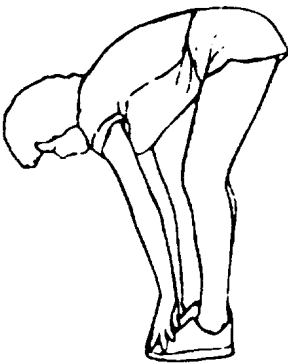

TOE TOUCHES

Slowly bend forward from your waist, letting your back and shoulders relax as you stretch toward your toes. Reach as far as you can and hold for 15 counts.

HAMSTRING STRETCHES

Extend your right leg. Rest the sole of your left foot against your right inner thigh. Stretch toward your toe as far as possible. Hold for 15 counts. Relax and then repeat with left leg.

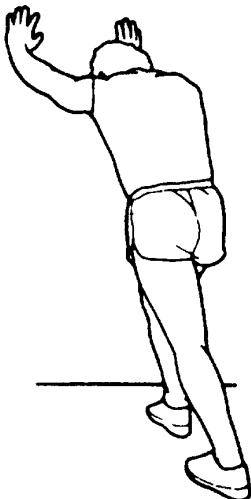
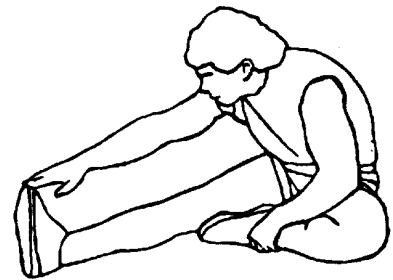

CALF/ACHILLES STRETCH

Lean against a wall with your left leg in front of the right and your arms forward. Keep your right leg straight and the left foot on the floor; then bend the left leg and lean forward by moving your hips toward the wall. Hold, then repeat on the other side for 15 counts.