

1164 (KH-32805)

PRO GYM

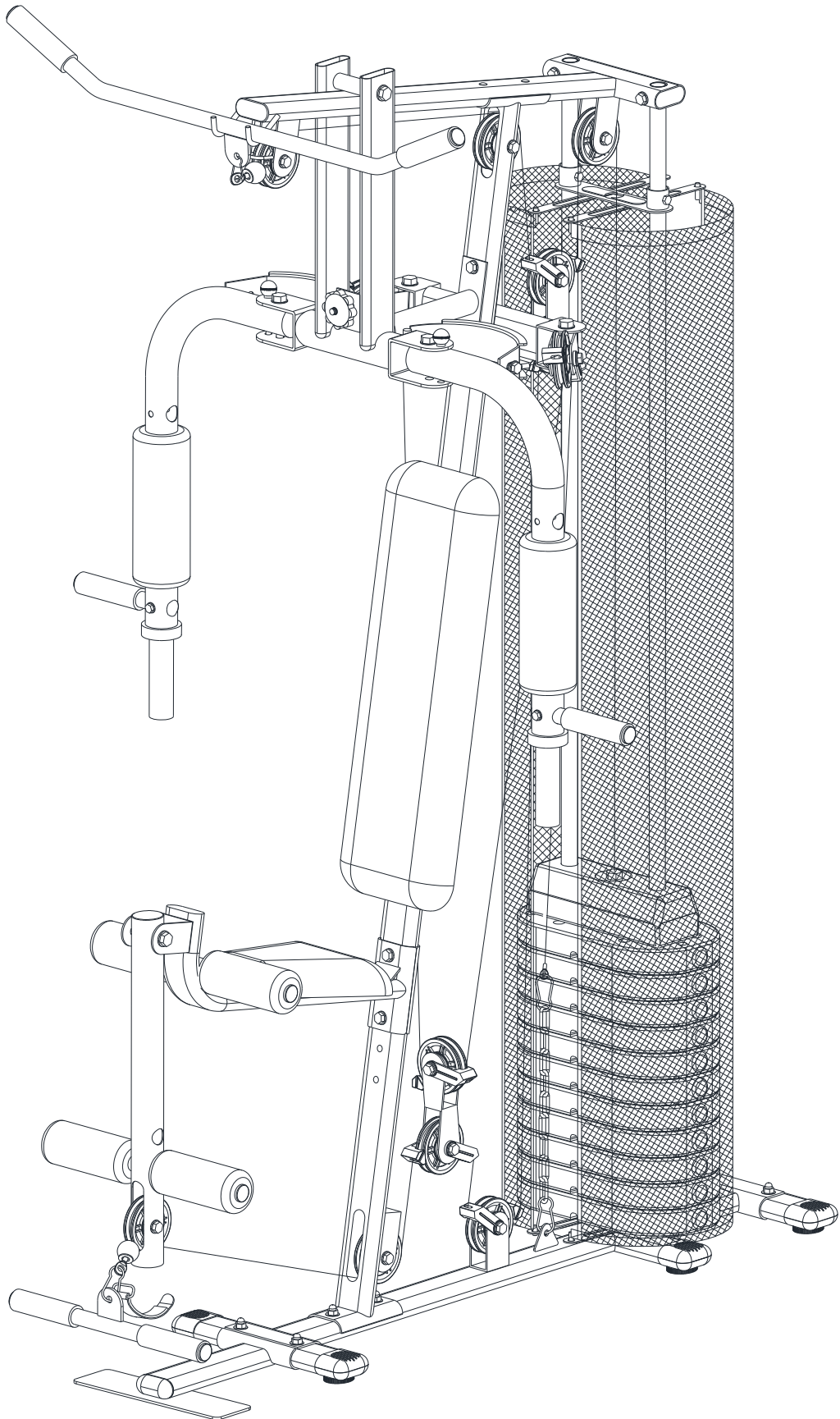

# CHECK LIST

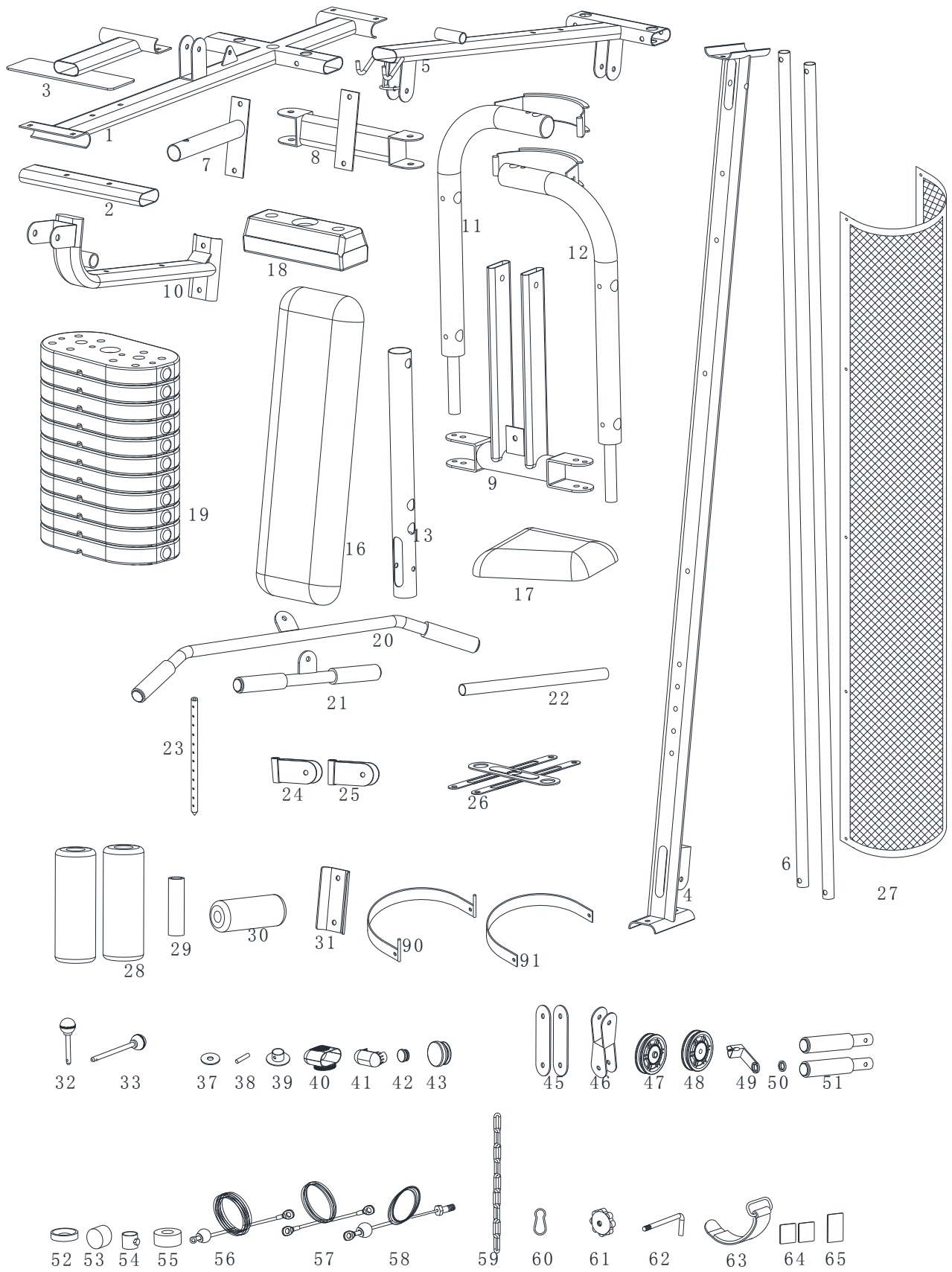























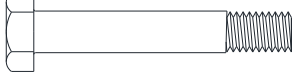

## LIST OF COMPONENTS

NO.	DESCRIPTION	Q'TY	NO.	DESCRIPTION	Q'TY
1	Main Base Hauptbasis Podstavec	1	50	Inner tube of pulley Innenrohr des Riemens Vnútoraná trubka remeňa	15
2	Stabilizing Base Stabilisierende Basis Stabilizačná tyčka	2	51	Hand grip Handgriff Rúčka	2
3	Anti-lift board Anti lift Platte Platňa	1	52	Hollow cap Hohle Kappe Dutá krytka	2
4	Front vertical beam Vorderer vertikaler Balken Predné vertikálne rameno	1	53	Foot cap Fußkappe Krytka nohy	1
5	Upper beam Oberer Balken Vrchné rameno	1	54	buffer of guidance Puffer der Führer Tlmič vodítka	2
6	Chrome Guides Chrom Führer Chrómové vodítka	2	55	Buffer Puffer Tlmič	2
7	Resist bar Widerstandsstange Tyčka	1	56	Cable III 4100L Kabel Lanko	1
8	Balance rod Zugstange Tiahlo	1	57	Cable I 3100L Kabel Lanko	1
9	press tube Pressrohr Trubica	1	58	Cable II 2415L Kabel Lanko	1
10	Seat Support Sitzträger Nosník sedačky	1	59	Chain (9links) Kette Reťaz	1
11	Right butterfly arm Rechter butterfly Arm Pravé rameno	1	60	Hook Haken Hák	4
12	Left butterfly arm Linker butterfly Arm Ľavé rameno	1	61	Knob 3/8"-16UNC-28L Knopf Otočný gombík	1
13	Leg extension rod Beinverlängerungsstange Predĺžovacia tyč	1	62	Fixing hook Fixierhaken Fixačný hák	1
16	Backrest Rückenlehne Opierka	1	63	Ankle strap Knöchelriemen Remeň	1
17	Seat	1	64	Buffer	2

	Sitz Sedačka			Puffer Tlmič	
18	Upper selector Oberer Auswähler Vrchné závažie	1	65	Buffer Puffer Tlmič	1
19	Lower selector Unterer Auswähler Spodné závažie	11	66	Bushing Buchse Púzdro	8
20	Upper pulley bar Obere Rollenstange Vrchné tiahlo	1	67	Bushing Buchse Púzdro	2
21	Lower pulley bar Untere Rollenstange Spodné tiahlo	1	68	Bushing Buchse Púzdro	2
22	Foam holder Schaumstoffhalter Držiak	2	69	Anti-loosen nut M6*1*6T Schraubenmutter Matka	20
23	Selector guide rod Führungsstange Vodiaca tyč	1	70	Anti-loosen nut M8*1.25*8T Schraubenmutter Matka	2
24	Left pulley bracket Linke Rollenklammer Ľavá svorka	1	71	Anti-loosen nut M10*1.5*10T Schraubenmutter Matka	22
25	Right pulley bracket Rechte Rollenklammer Pravá svorka	1	72	Anti-loosen nut M12*1.75*12T Schraubenmutter Matka	6
26	Cover fixing plate Abdeckungs-Befestigungsplatte Držiak sedačky	2	73	Domed nut M8x1.25x15L Schraubenmutter Matka	8
27	Shroud Hülle Kryt	2	74	Flat washer D14*D6.5*0.8T Flache Beilagscheibe Podložka	42
28	Big foam D47*D90*250L Großer Schaumstoff Pena	2	75	Flat washer D19xD8.3x1.6t Flache Beilagscheibe Podložka	12
29	Small foam D23*D35*127L Kleiner Schaumstoff Pena	8	76	Flat washer D20*D11*2T Flache Beilagscheibe Podložka	46
30	Foam D23*D70*170L Schaumstoff Pena	4	77	Flat washer D24*D13.5*2.5T Flache Beilagscheibe Podložka	12
31	Reinforcing board Verstärkungsplatte Zosilňovacia platňa	1	78	square neck bolt M8x1.25x45L Rundschrabe Šroub	8
32	Ball pin Kugelbolzen Kíb	2	79	Hex bolt M6*1*15L Sechskantschraube Šroub	22

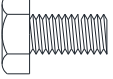

33	Weight selection pin Stift für die Gewichts Auswahl Kolík zmeny závažia	1	80	Hex bolt M8*1.25*60L Sechskantschraube Šroub	2
37	Weight fixing washer Gewichtsbefestigungsscheibe Podložka upevnenia závažia	1	81	Hex bolt M10*1.5*45L Sechskantschraube Šroub	4
38	Weight fixing pin Stift für die Gewichtsfixierung Kolík upevnenia závažia	1	82	Hex bolt M10*1.5*50L Sechskantschraube Šroub	5
39	Weight fixing cover Abdeckung zur Gewichtsfixierung Krytka	1	83	Hex bolt M10*1.5*55L Sechskantschraube Šroub	2
40	Foot cap (oval) Ovale Fußkappe Oválna krytka nohy	6	84	Hex bolt M10*1.5*60L Sechskantschraube Šroub	7
41	End cap (oval) Ovale Endkappe Oválna koncová krytka	5	85	Hex bolt M10*1.5*65L Sechskantschraube Šroub	1
42	End cap (round) Runde Endkappe Okrúhla koncová krytka	14	86	Hex bolt M10*1.5*85L Sechskantschraube Šroub	5
43	End cap (round) Runde Endkappe Okrúhla koncová krytka	4	87	Hex bolt M12*1.75*80L Sechskantschraube Šroub	5
45	Pulley plate Riemenscheibe Držiak remenice	2	88	Hex bolt M12*1.75*135L Sechskantschraube Šroub	1
46	Double pulley bracket Doppelscheibenhalterung Dvojité držiak	1	89	Hex bolt M10*1.5*25L Sechskantschraube Šroub	2
47	Raised pulley Angehobene Riemenscheibe Remenica	9	90	Reforcing plate set Verstärkende Platte Zosilňujúca platňa	4
48	Flat pulley Flache Riemenscheibe Remenica	3	91	Reforcing plate Verstärkende Platte Zosilňujúca platňa	6
49	Pulley guide plate Riemenführungsplatte Vodítka remeňa	15			

## Screw bag

78		M8x45	x8	66		D29*D12.1*9T	x8
79		M6x1x15	x20	67		D18*D10.2*24T	x2
80		M8x60	x2	68		D18*D10*18.5T	x2
81		M10x45	x4	69		M6*1*6T	x20
82		M10x50	x5	70		M8*1.25*8T	x2
83		M10x55	x2	71		M10*1.5*10T	x22
84		M10x60	x7	72		M12*1.75*12T	x6
85		M10x65	x1	73		M8x15	x8
86		M10x85	x5	74		D14*D6.5*0.8T	x40
87		M12x80	x5	75		D19*D8.3*1.6T	x12
88		M12x135	x1	76		D20*D11*2T	x46
89		M10x25	x2	77		D24*D13.5*2.5T	x12

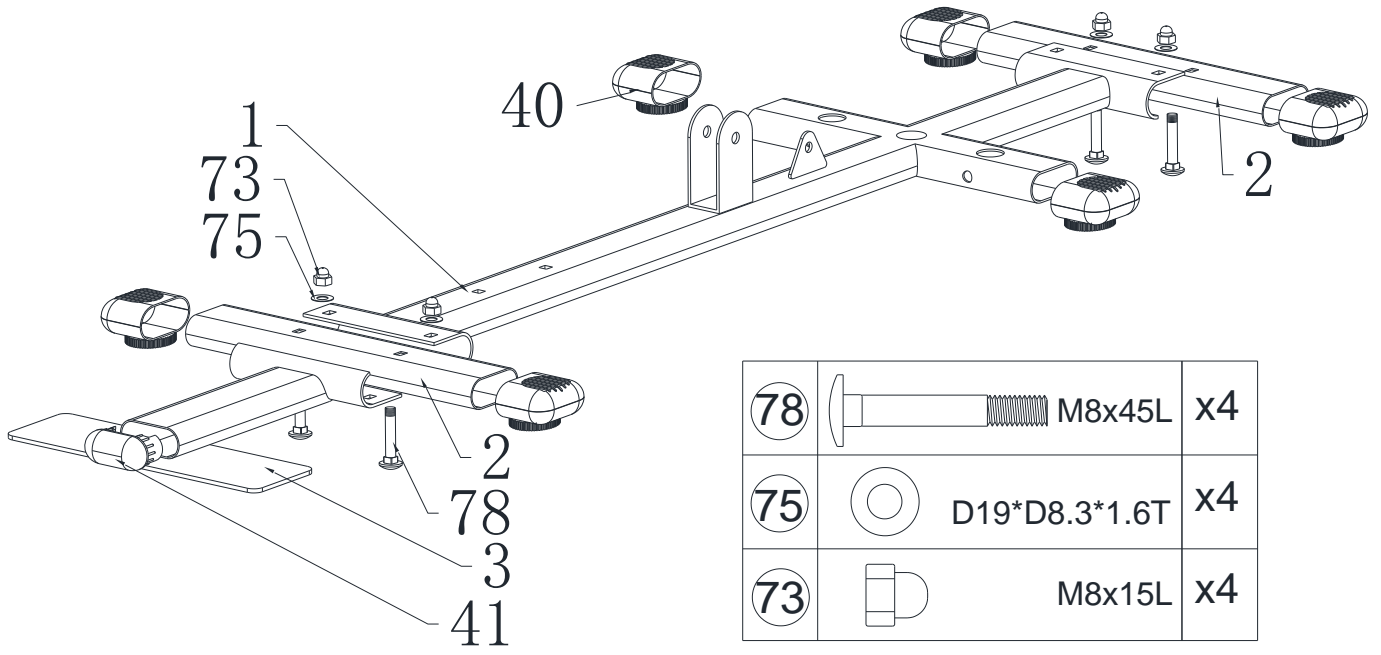





**STEP 1**



78		M8x45L	x4
75		D19*D8.3*1.6T	x4
73		M8x15L	x4

**FIG.1**

**STEP 2**

78		M8x45L	x2
75		D19*D8.3*1.6T	x2
73		M8x15L	x2
86		M10x1.5x85	x2
76		D20*D11*2T	x4
71		M10*1.5*10T	x2

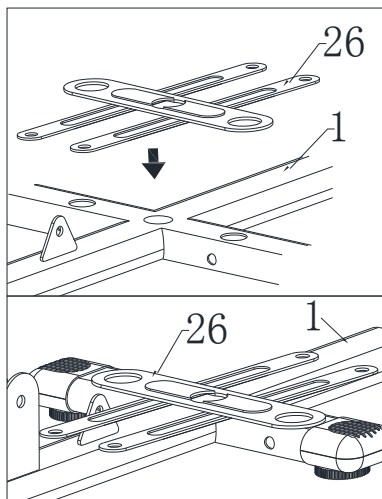
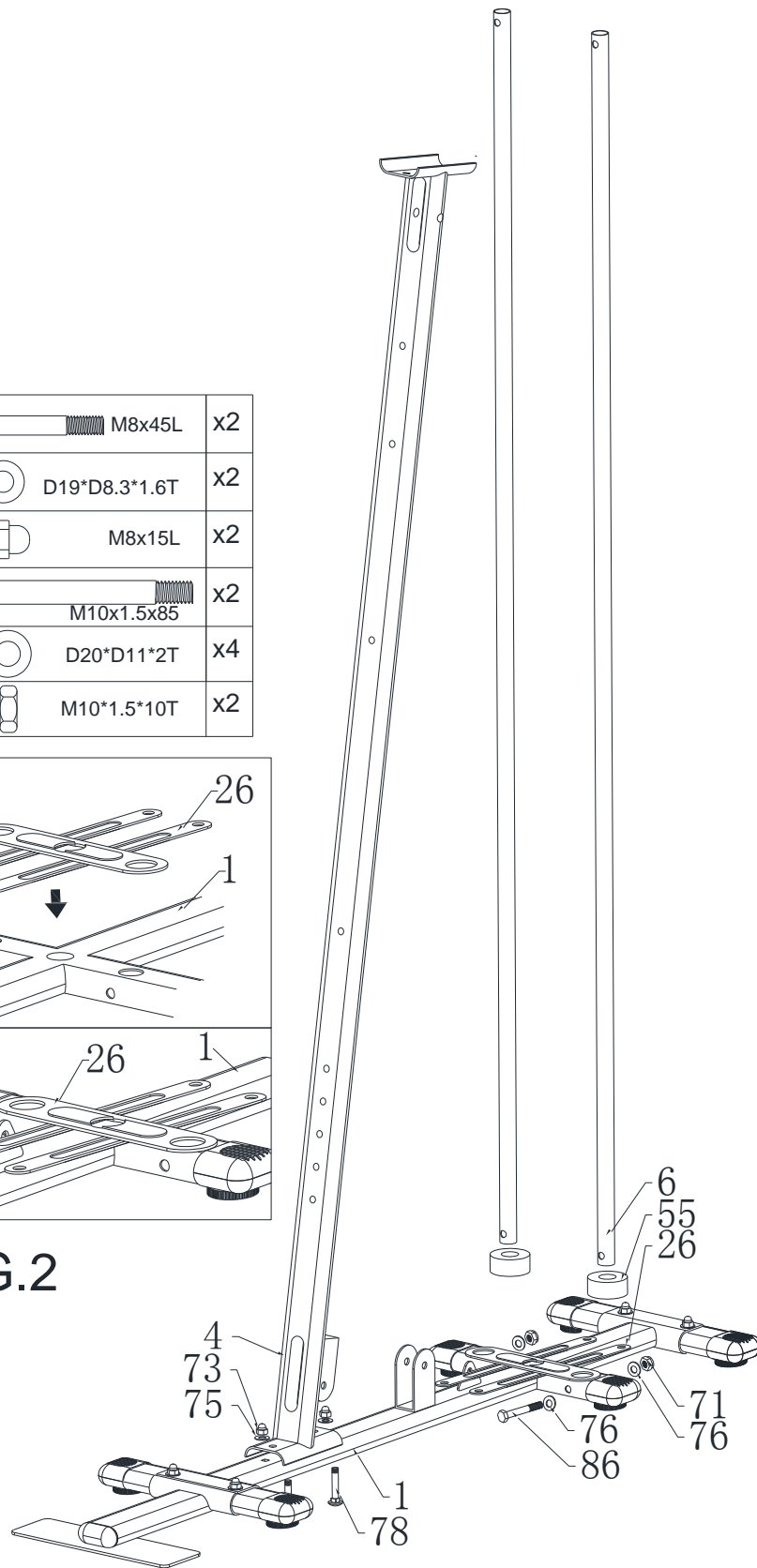
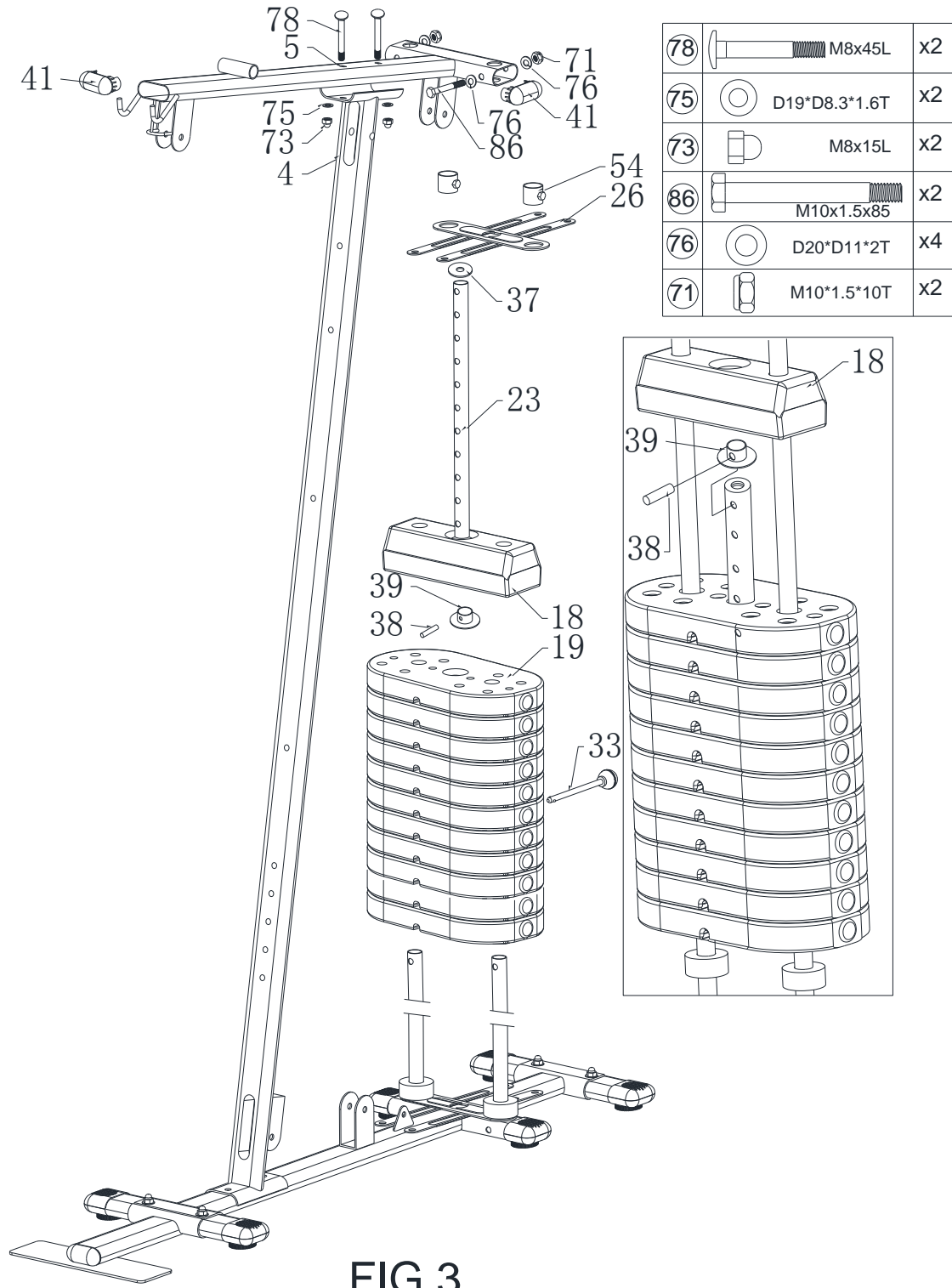

FIG.2



STEP 3





STEP 4

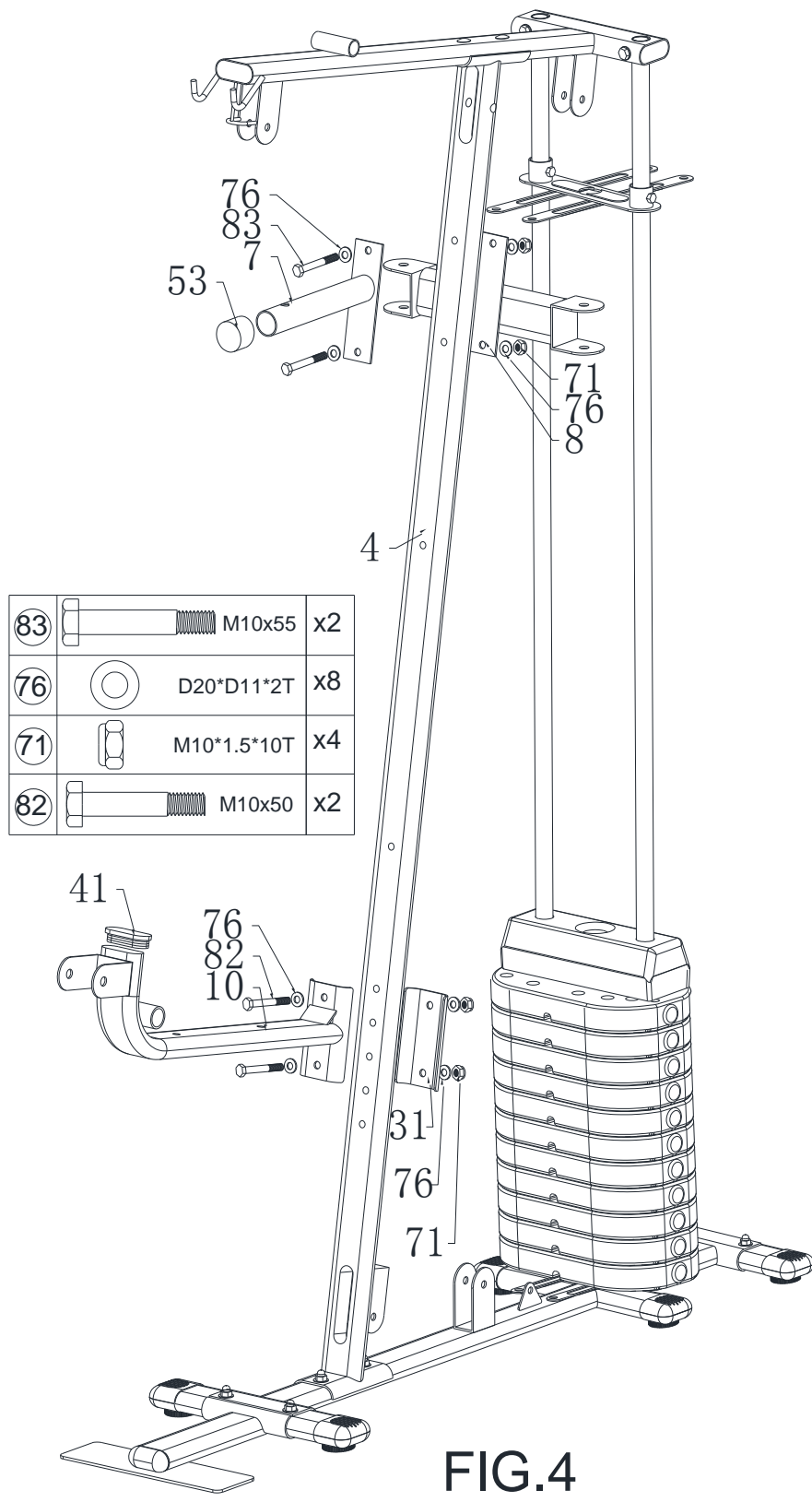
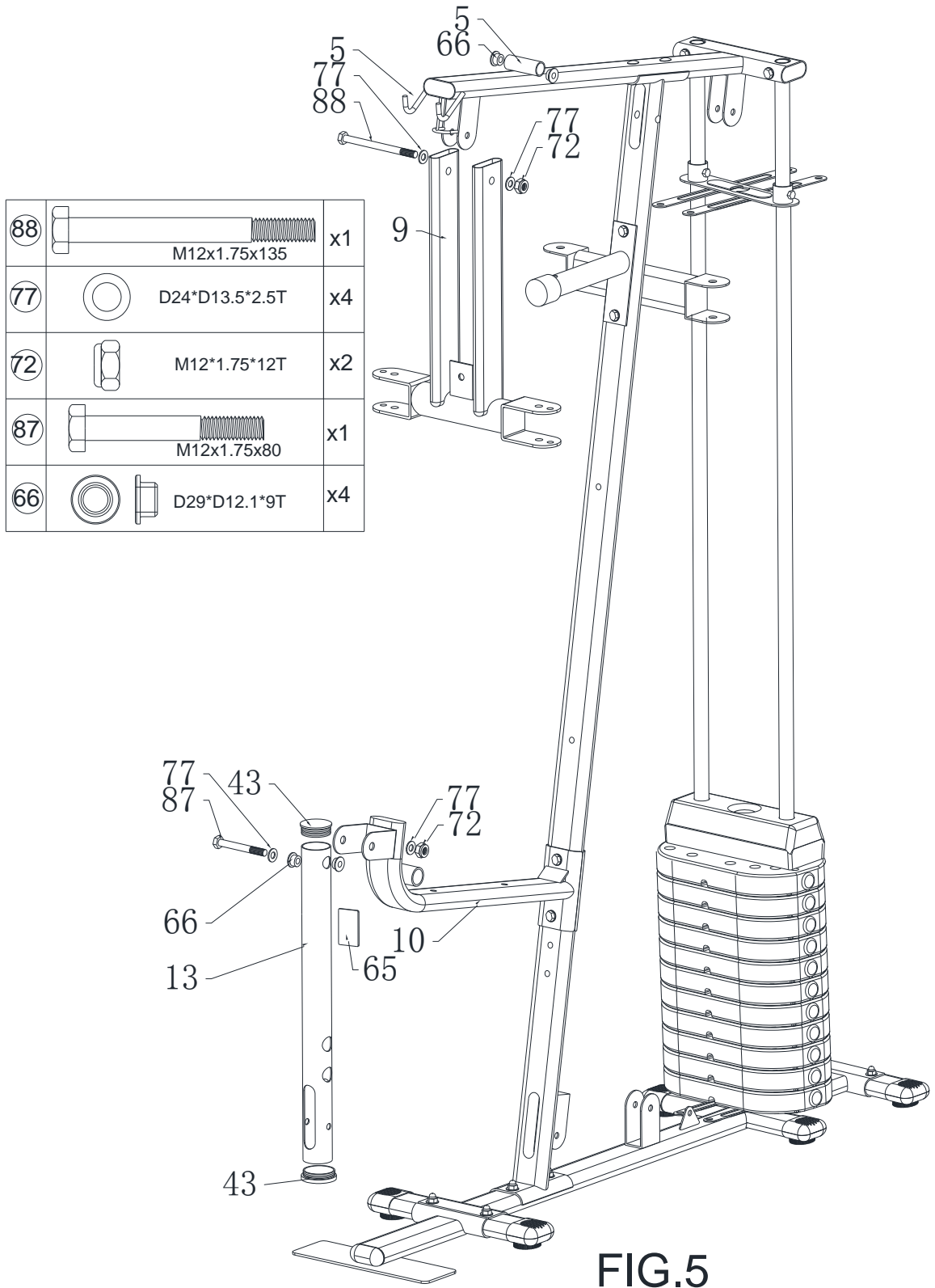

FIG.4

STEP 5



**STEP 6**

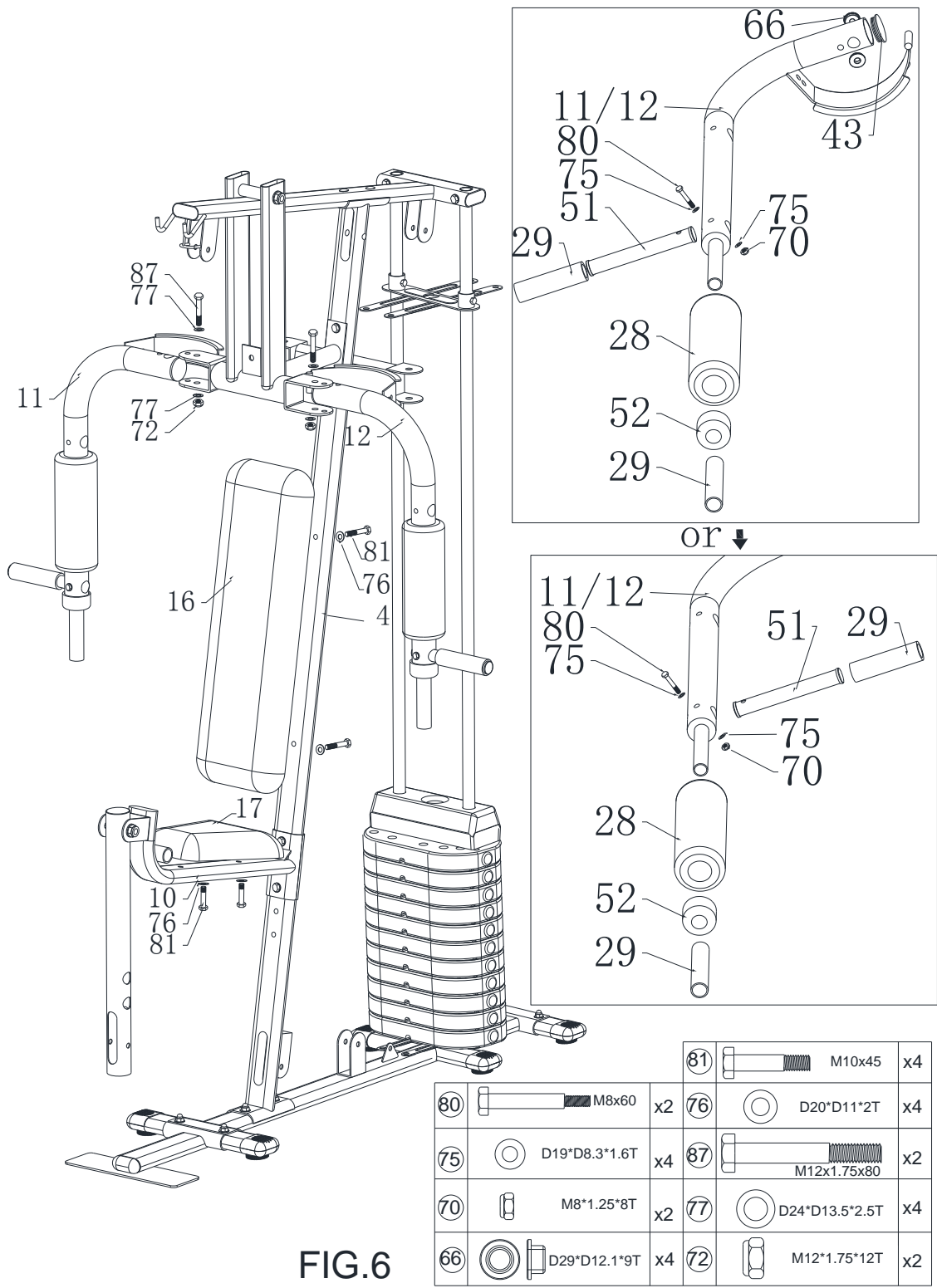
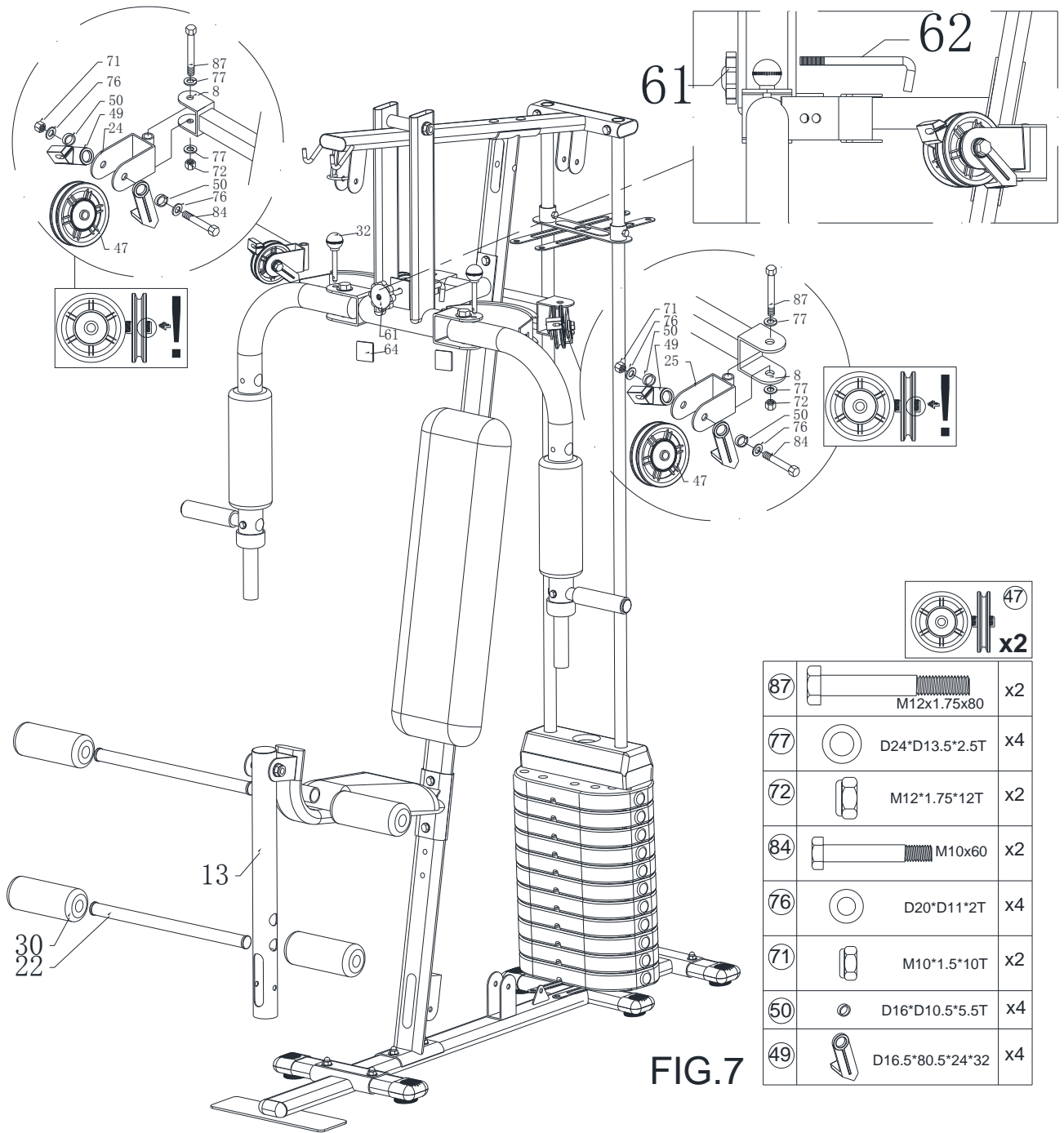

FIG.6

81		M10x45	x4
80		M8x60	x2
76		D20*D11*2T	x4
75		D19*D8.3*1.6T	x4
87		M12x1.75x80	x2
70		M8*1.25*8T	x2
77		D24*D13.5*2.5T	x4
66		D29*D12.1*9T	x4
72		M12*1.75*12T	x2

STEP 7



**STEP 8**

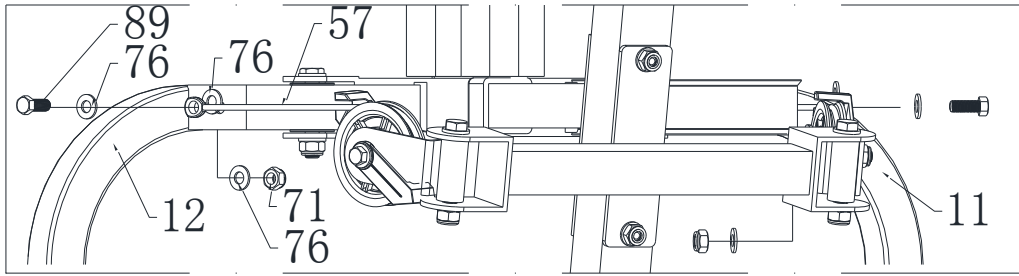

89		M10x25	x2
76		D20*D11*2T	x10
71		M10*1.5*10T	x4
84		M10x60	x2
50		D16*D10.5*5.5T	x4
49		D16.5*80.5*24*32	x4

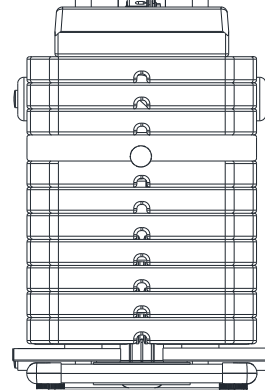
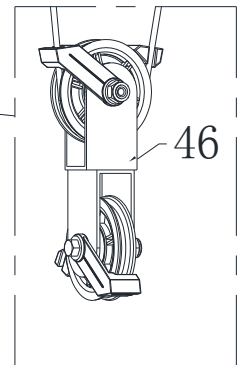
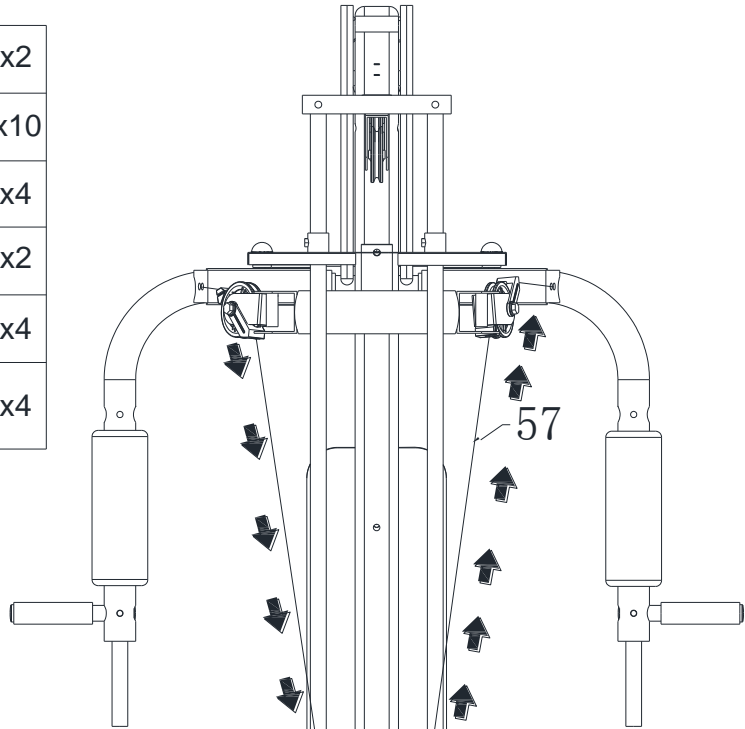
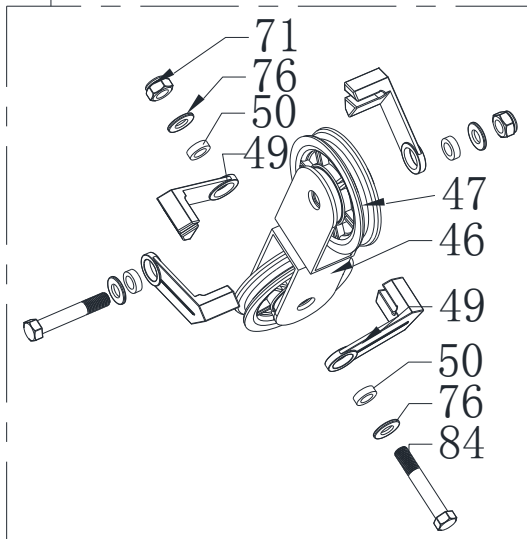
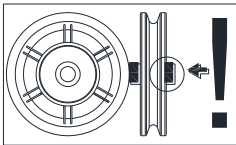
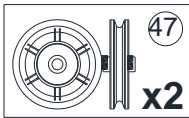
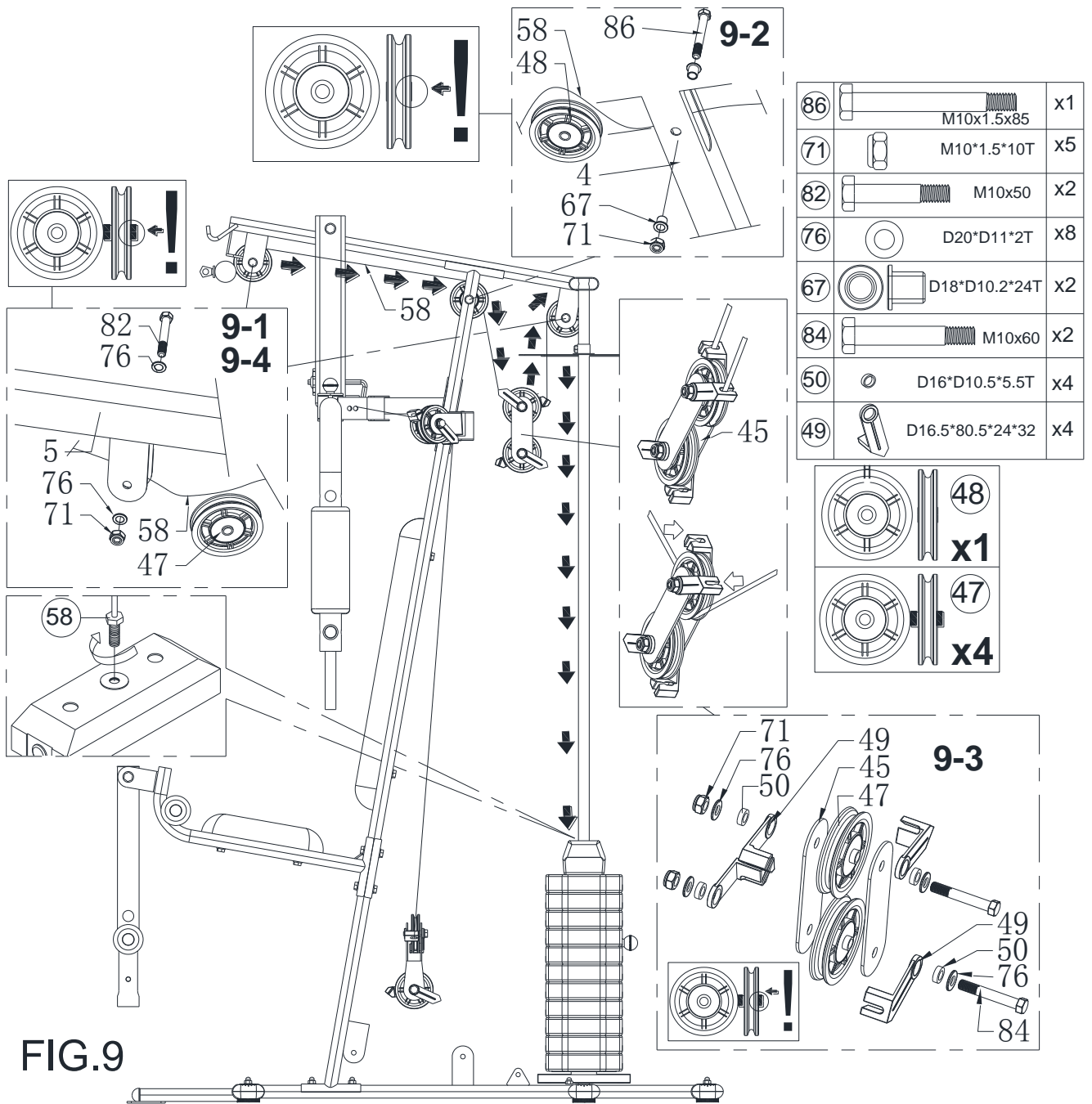

FIG.8

STEP 9



STEP 10

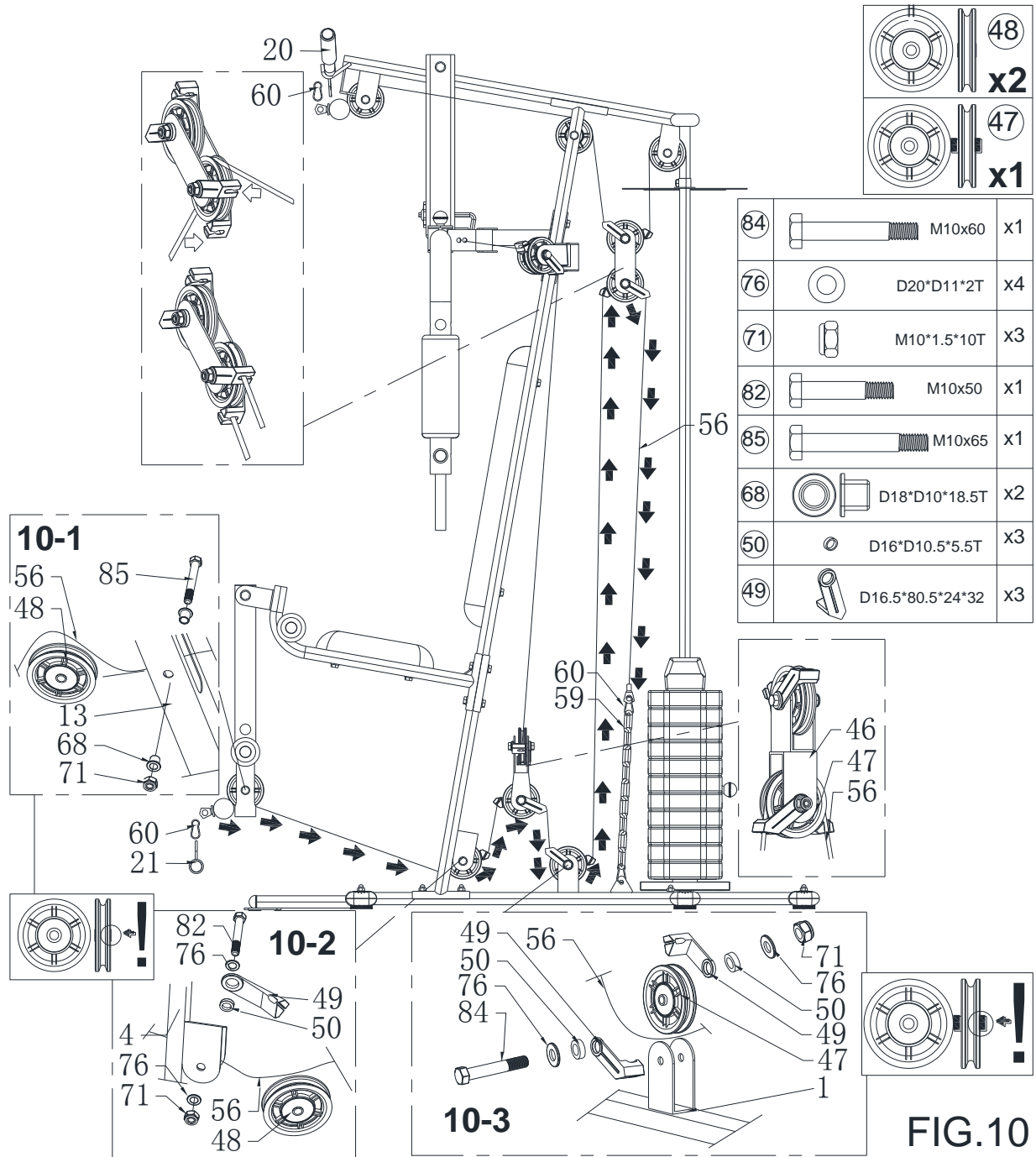
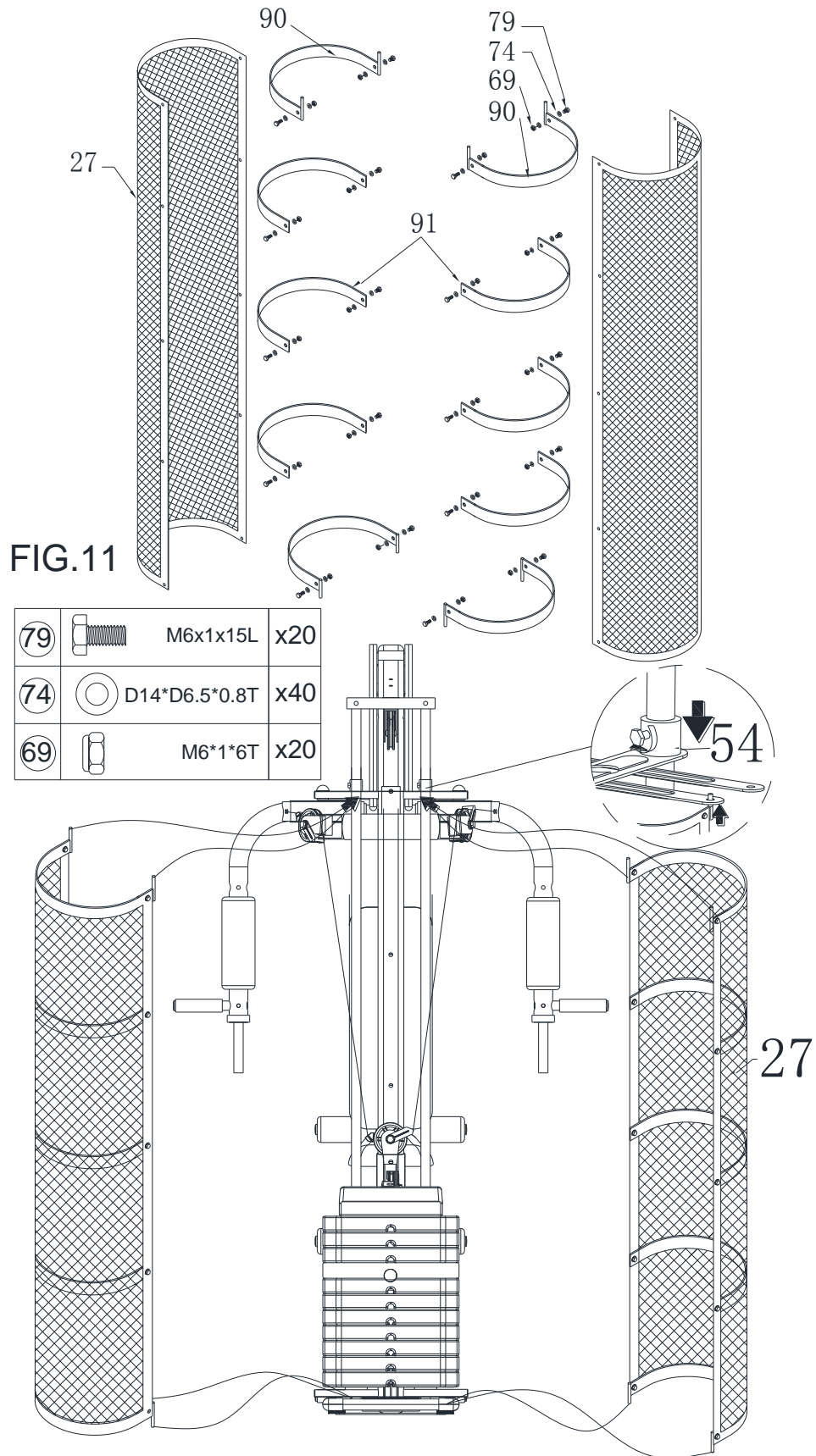

FIG.10

STEP 11





Exploding drawing

