

Termék szám 69787

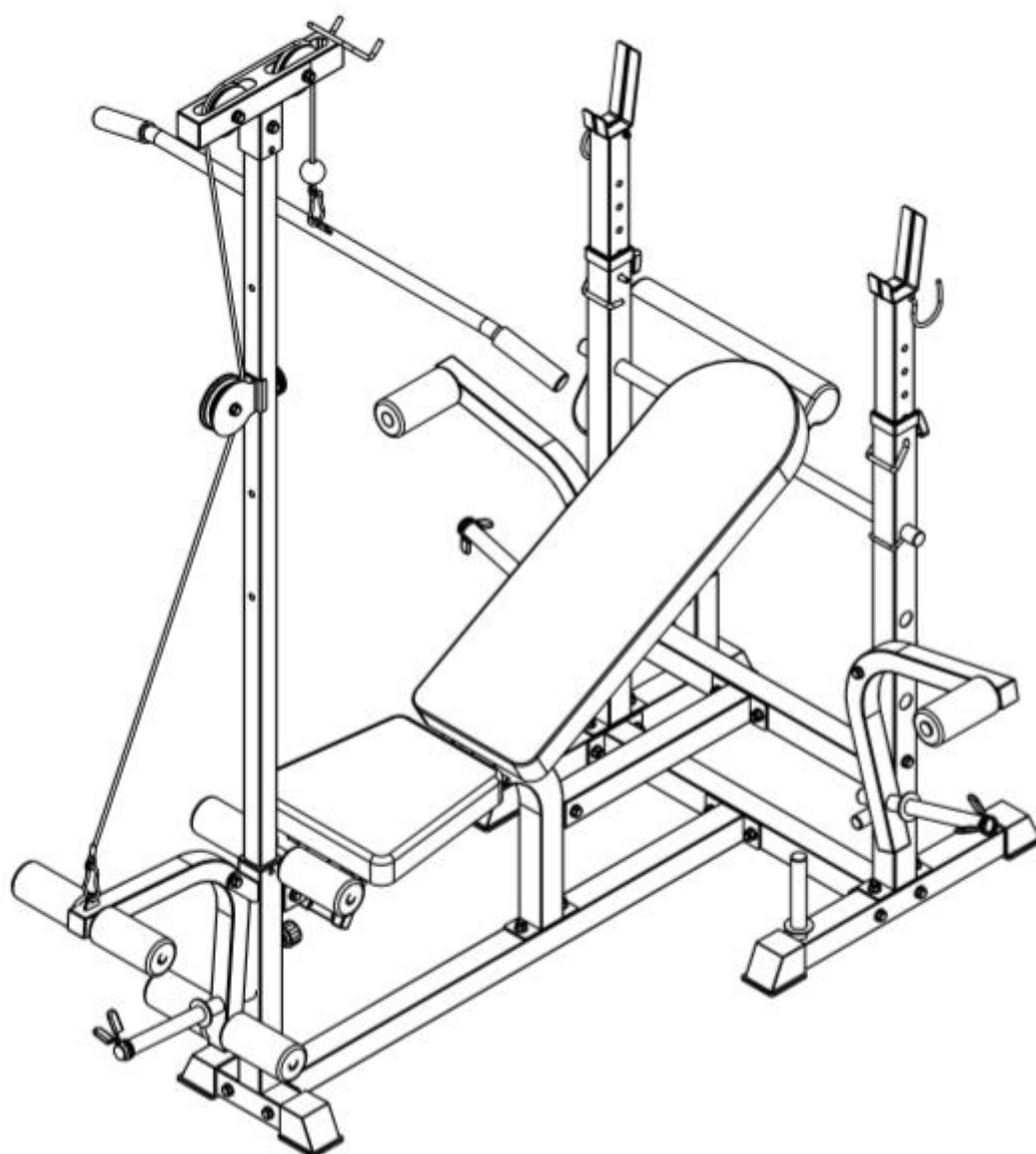









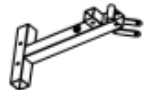













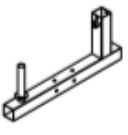

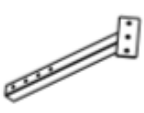





















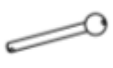

Használati utasítás





Használat előtt olvassa el figyelmesen az összes utasítást és figyelmeztetést. Az utasítások be nem tartása súlyos sérülést, halált okozhat. Ellenőrizze a terméket, hogy minden tartozéka meg legyen. A terméket csak eredeti alkatrészeivel használja. Soha ne próbálja meg javítani a terméket.

Figyelmeztetés a személyes biztonság érdekében

- Ez a termék kizárólag otthoni használatra készült, nem kereskedelmi vagy terápiás célra.
- A berendezés körül legalább 0,6méteres területet szabadon kell hagyni.
- Ez a berendezés nem játék. Gyermekek nem használhatják. Tartsa gyermekeit távol a berendezéstől.
- Ezt a terméket 120 kg-nál nagyobb súlyú személyek nem használhatják.
- A berendezés használata előtt mindig ellenőrizze le, hogy az anyák és csavarok megfelelően meg legyen húzva.
- Ha szokatlan zajokat hall, azonnal hagyja abba az edzést míg meg nem találta az okát.
- A berendezés használata közben viseljen megfelelő ruházatot. Kerülje a laza ruházatot, ami beakadhat a berendezésbe, vagy korlátozhatja a mozgást.
- Óvatosan kell eljárni a berendezés mozgásánál, vagy emelésénél.
- Lehetőleg stabil és vízszintes alapra helyezzük.
- Rendszeresen ellenőrizze le a terméket.
- A hibás alkatrészeket cserélje ki.

1 	2 	3 	4 	5 
6 	7 	8 	9 	10 
11 	12 	13 	14 	15 
16 	17 	18 	19 	20 
21 	22 	23 	24 	25 
26 	27 	28 	29 	30 
31 	32 	33 	34 	35 
36 	37 	38 	39 	40 
41 				

42  M10X125-2	43  M10X70-22	44  M10X65-4	45  M10X45-1	46  M10X25-2
47  M8X40-8	48  M8X20-2	49  Ø 10-60	50  Ø 8-10	51  M10-29

<p>52</p>  <p>M6-2</p>	<p>53</p>  <p>X1</p>	<p>54</p>  <p>X1</p>	<p>55</p>  <p>X2</p>
---	---	---	---

Lépés 1

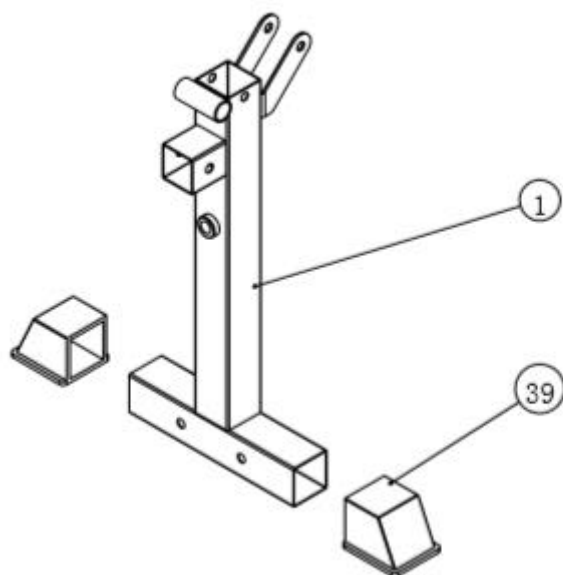

Lépés 2

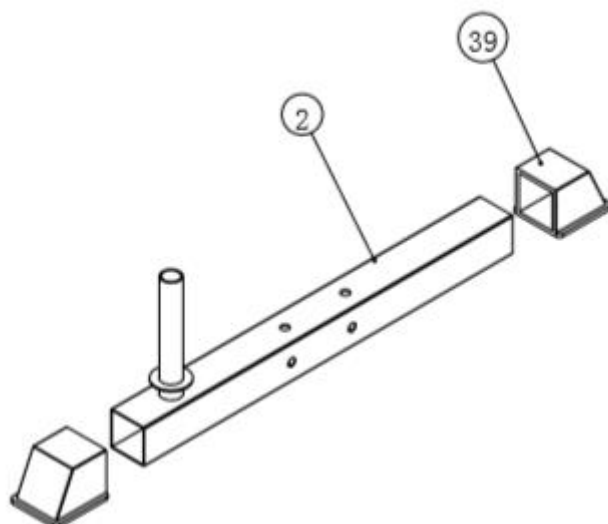

Lépés 4

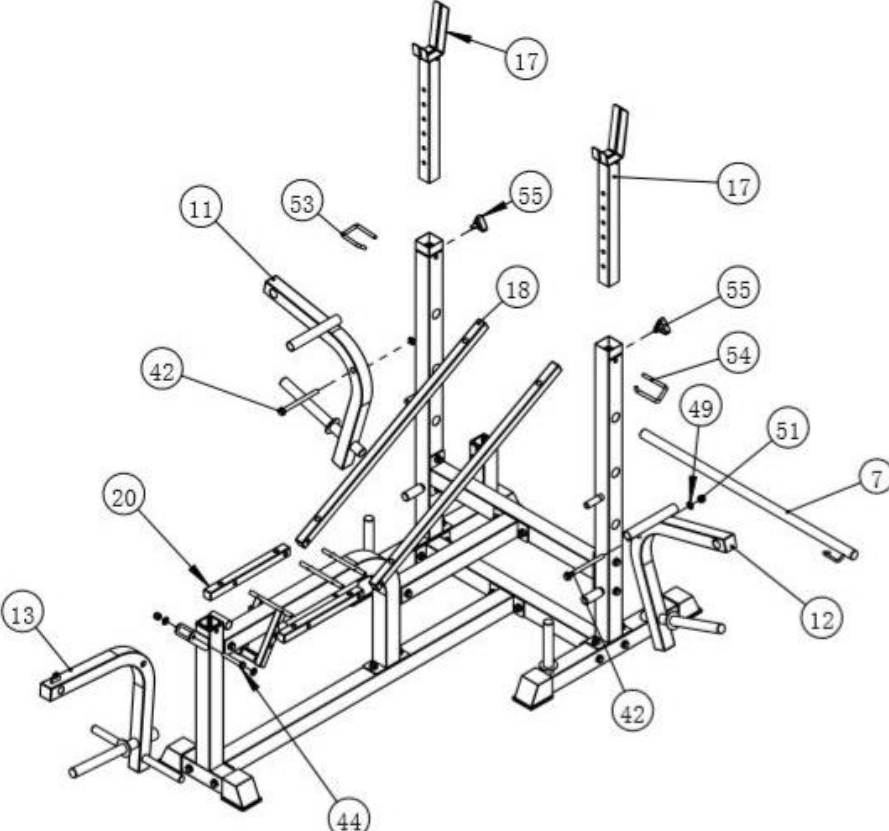

Lépés 5

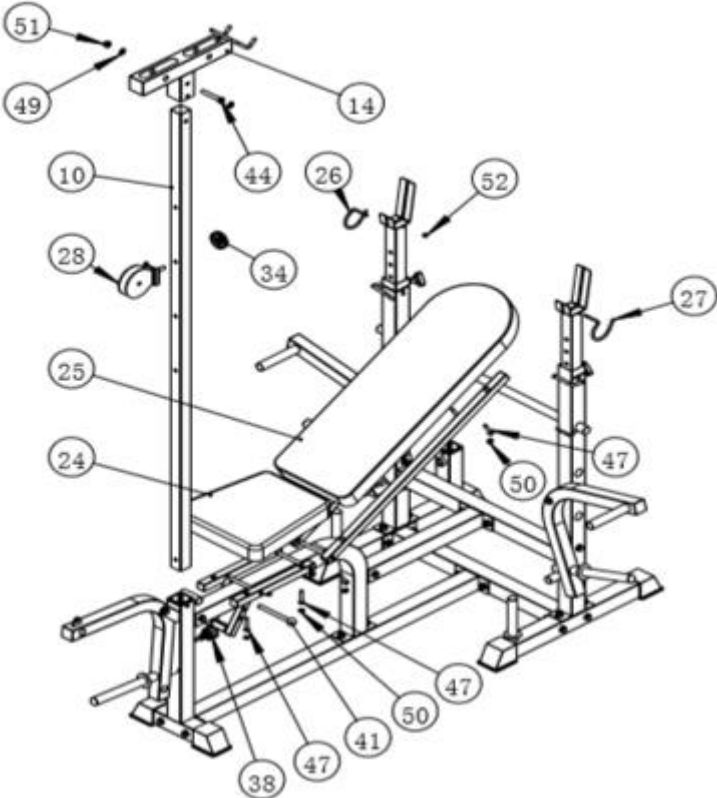

Lépés 6

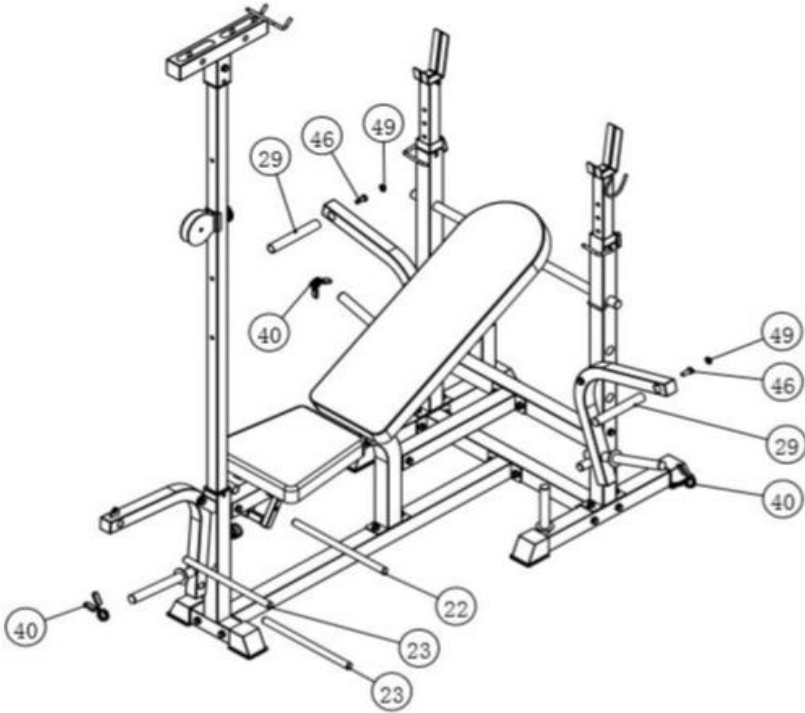

Lépés 7

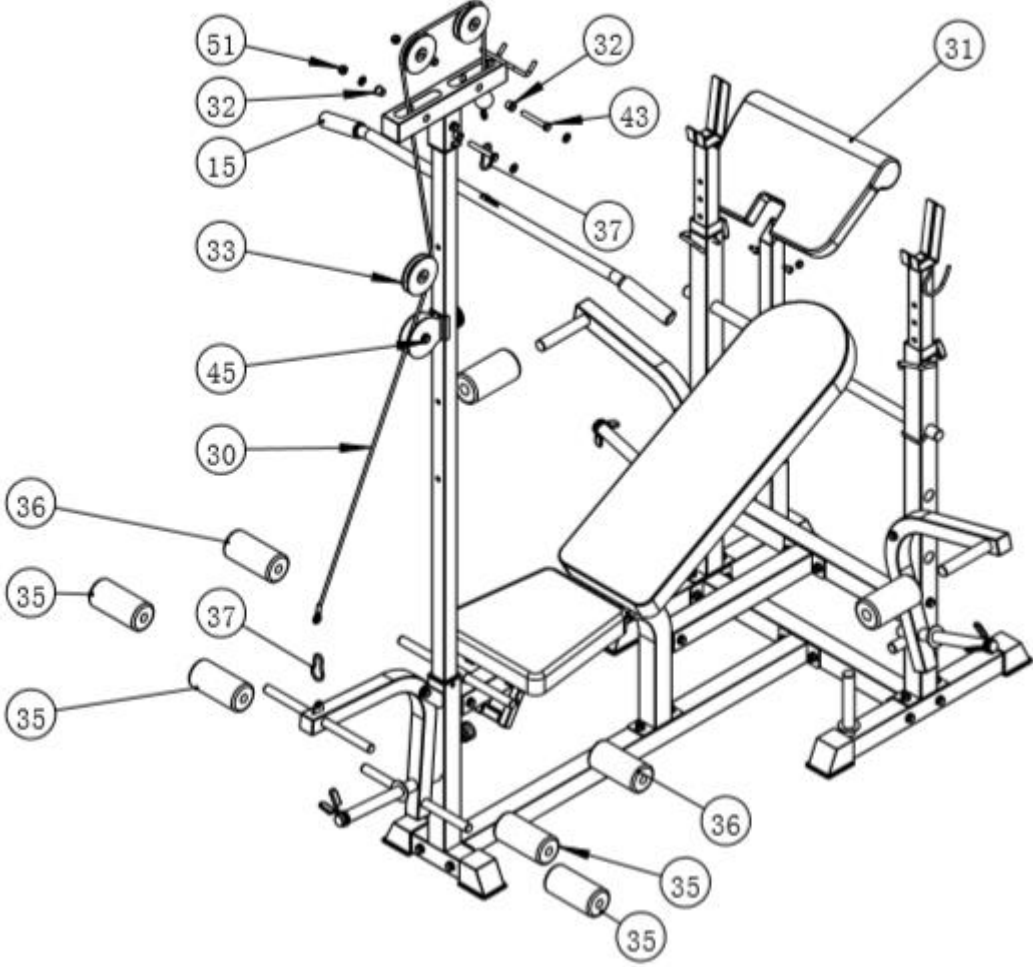

Lépés 8

