

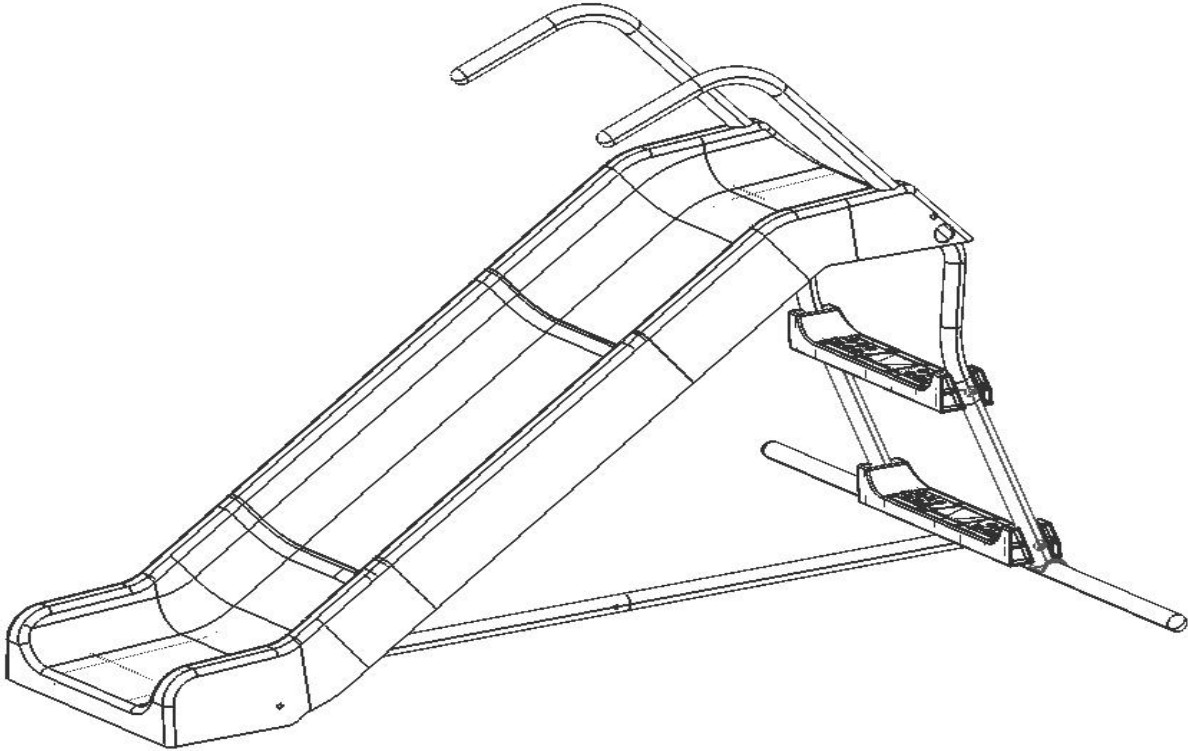

# Stair Slide Assembly Instructions



CE



Page 1 of 9

## **SAFETY NOTES**

To prevent damage and accidents to persons and/or property, please read the following:

1. Thoroughly read all parts of this manual and follow the instructions before using.

2. Do not use any accessories other than those provided and /or specified by the manufacturer.
3. This equipment must be assembled and checked by an adult.
4. Retain complete instructions for future reference.
5. Check all nuts and bolts and tighten when required.
6. Check all coverings and bolts for sharp edges and replace when required.
7. Place the Top Slide Chute on a level surface. Ensure the Bottom Slide Chute is at least 40 feet (1 meter) away from any structure or obstruction, such as door, wall, or furniture.
8. Other persons must not be allowed to stand within the range of motion of the person using the equipment.
9. DO NOT install this equipment where the metal parts may be scratched or scraped.
10. DO NOT install this equipment over concrete, asphalt or any other hard surface.
11. Leave all fittings finger tight until assembly is complete (for ease of assembly)- then tighten firmly.
12. Always supervise young children at play.
13. This item is not designed for adults. The maximum weight of 1 child is not to exceed 77 lbs (35kgs).
14. DO NOT allow children to stand on the slide chute.
15. DO NOT allow loose, baggy (or hooded) clothes to be worn, to prevent them being trapped and unable to free themselves.
16. DO NOT allow children to climb on parts on this equipment not intended for this purpose.
17. Regularly check the item for wear and damage, refrain from use until necessary parts are replaced.
18. Please remove all packaging including shrunk-on film, polybag, carton, pallet, ...etc. before giving to a child.
19. This product is for home use only and has not been designed for commercial use in play fitness centers, nurseries, etc.
20. Failure to assemble this item as per the instruction may cause injury to the user.
21. Age suitability: 3-10 years.

# COMPONENT LIST

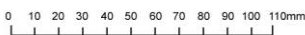

**A**   
M6 15mm bolt (x 2)

**B**   
M6 35mm bolt (x 11)

**D** 

**J**   
Top slide chute (x 1)

**K**   
Tie bar (x 1)

**L** 

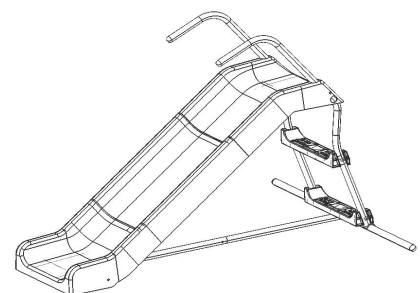

**Q** 

M6 washer (x 7)



Spring washer (x 7)



Domenut (x 7)



Tie bar (x 1)

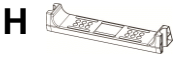

Ladder step (x 2)

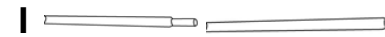

Ladder stabilizer bar (x 1)

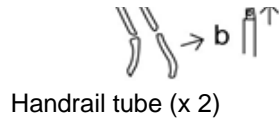

Handrail tube (x 2)



1/4" x 5/8" (x 4)



Spanner (x 1)



Ground anchor (x 2)

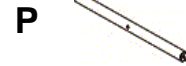

Chute bottom support tube (x 1)

M4 x 14mm (x 4)



Plastic cap (x 4)



M6 square washer (x 4)

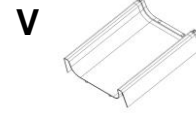

Middle slide chute (x 1)

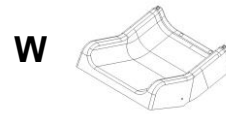

Bottom slide chute (x 1)

### TOOL REQUI

1. Philips head screw driver



2. Combination Wrench 10

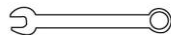

3. Rubber Mallet



Steel plate (x 2)

## Assembly Steps:

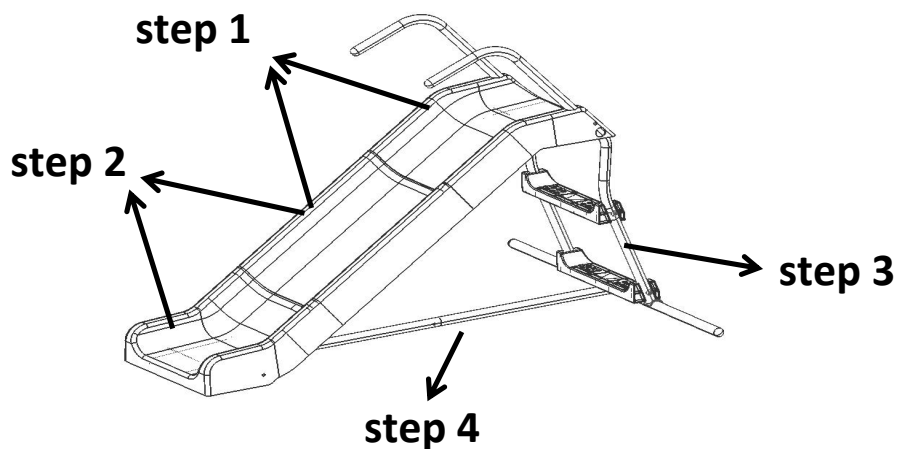

**Step 1** Assembling the Top slide chute and the Middle slide chute (V)

- 1 - 1. The Top slide chute (J) and the Middle slide chute (V) have tongue-and-groove joint on the edge for the connection.
- 1 - 2. Turn the Top slide chute (J) and the Middle slide chute (V) to the back side. (Figure 1)
- 1 - 3. Connect the top slide chute (J) and Middle slide chute (V) by embedding tongue-and-groove joint firmly. (Figure 2)

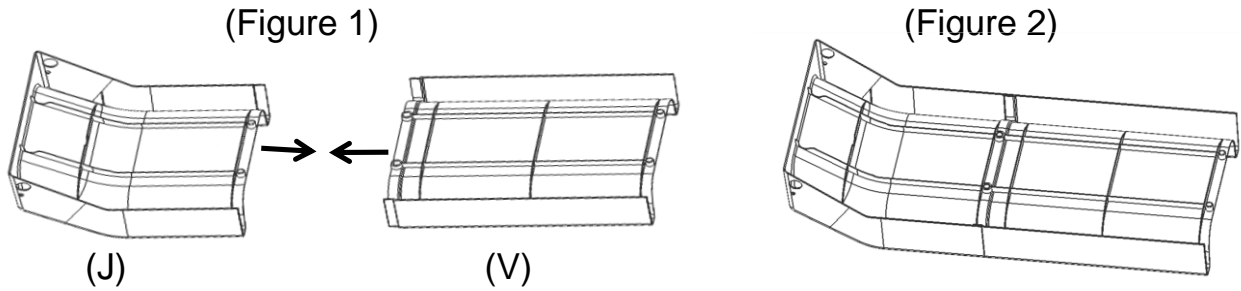

**NOTE:** The easiest way to install the two chute pieces is to lay both of them flat on a table, with the backside facing up -- towards you. Connect the pieces together as closely as you can. With your heel of your hand, press down on the connection point until there is no gap. Doing this on a table is best, as you can remain standing and give more pressure to the heel of your hand, as needed.

- 1 - 4. Turn the Top slide chute (J) and the Middle slide chute (V) onto the logo side. Use a rubber mallet to strike on the edge of connection.

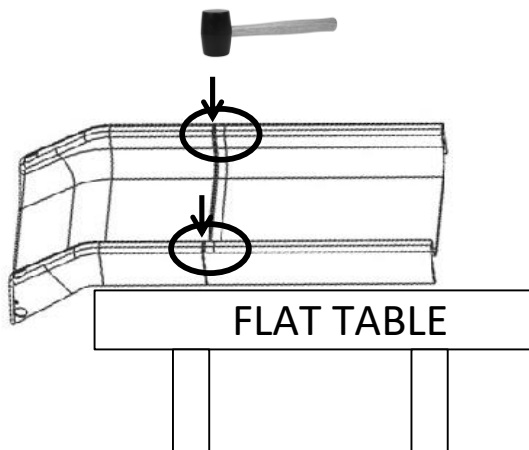

**NOTE:** Please ensure that the slide pieces connect without any gaps.

- 1 - 5. Fasten the Top slide chute (J) and the Middle slide chute (V) together by using the steel plate (X) x 1 and bolt (Q) x 2. (Figure 3)



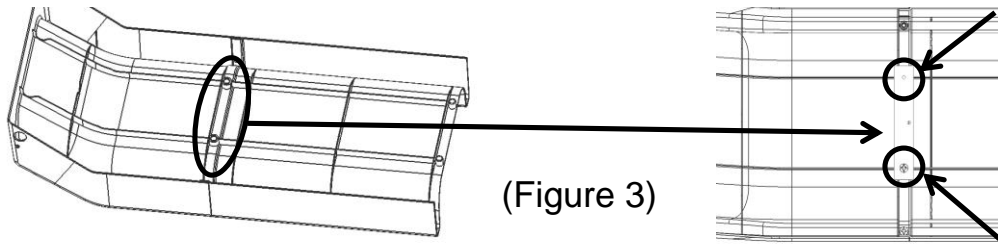

(Figure 3)

- 1 - 6. Bolt the edge of Top slide chute (J) and the Middle slide chute (V) by using bolt (M) x 2. (Figure 4)

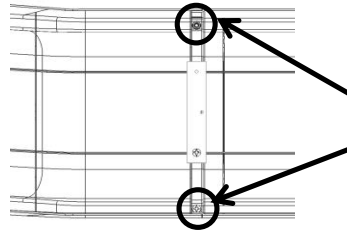

(Figure 4)

## Step 2 Adding the Bottom slide chute (W)

- 2 - 1. Lay out the slide chute of Step 1 and the Bottom slide chute (W). (Figure 1)  
 2 - 2. Connect the slide chute of Step 1 and the Bottom slide chute (W) by embedding tongue-and-groove joint firmly. (Figure 2)

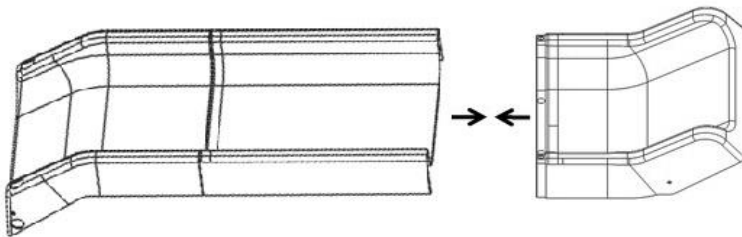

the slide chute of Step 1

(W)

(Figure 2)

(Figure 1: Front view of the slide chute of Step 1 and Bottom slide chute)

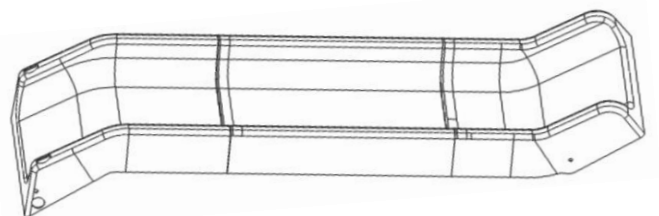

**NOTE: Please ensure that the slide pieces connect without any gaps.**

- 2 - 3 . Turn the slide chute of Step 2 - 2. to the back side.  
 2 - 4 . Fasten the slide chute of Step 1 and the Bottom slide chute (W) by using the steel plate (X) x 1 and bolt (Q) x 2. (Figure 3)

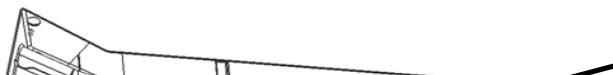

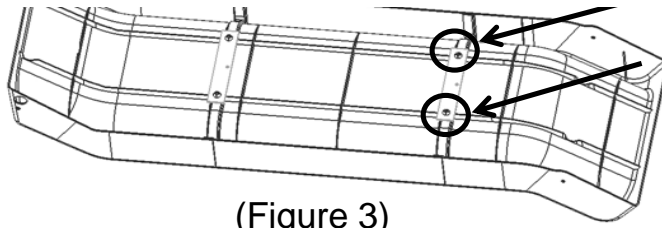

(Figure 3)

- 2 - 5. Bolt the edge of the Middle slide chute (V) and the Bottom slide chute (W) by using bolt (M) x 2. (Figure 4)

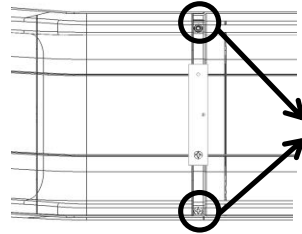

(Figure 4)

## Step 3 Assembling the Top/Bottom handrail and the ladder

- 3 - 1. Connect the ladder stabilizer bar (I) together.  
 3 - 2. Insert the plastic cap (R) to the both sides of the ladder stabilizer bar (I).  
 3 - 3. Fasten the bottom handrail tube (L - b) to the ladder stabilizer bar (I) by using bolt (B) x 1 + washer (D) x 1+ spring washer (E) x 1 and dometnut (F) x 1. (Figure 1)  
 3 - 4. Fasten the ladder step (H) to the bottom handrail tube (L - b) by using bolt (B) x 1 + square washer (U) x 1. (Figure 2)

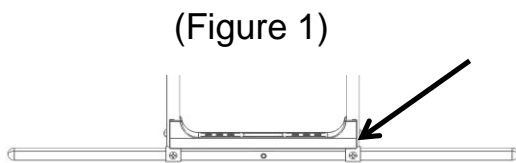

(Figure 1)

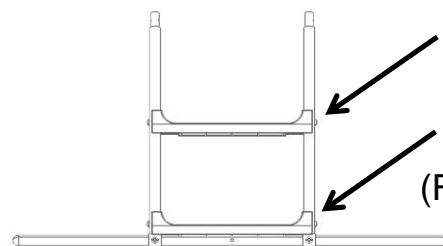

(Figure 2)

- 3 - 5. Insert the top handrial tube (L - a) to the bottom handrail tube (L - b). (Figure 3)

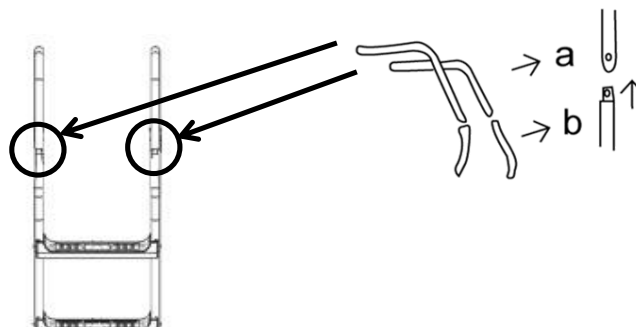

(Figure 3)



- 3 - 6. Make the slide chute of Step 2 into the Top handrail tube (L - a) of Step 3 - 5. together by using bolt (B) x 1 + washer (D) x 1+ spring washer (E) x 1 and dometut (F) x 1. (Figure 4) Insert plastic cap (R) into the top of handrail tubes and both side of ladder stabilizer bar.

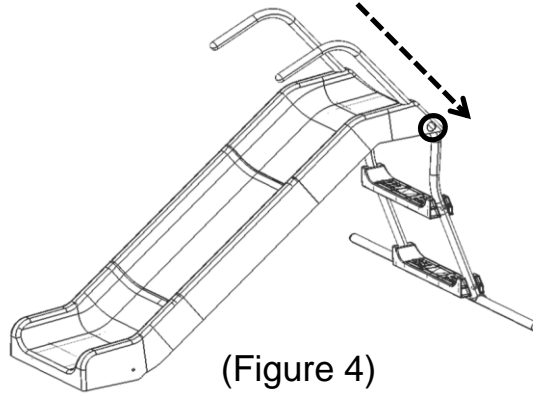

(Figure 4)

Page 7 of 9

## Step 4 Assembling the Tie Bar

- 4 - 1. Fasten the tie bar (G) and (K) together by using bolt (B) x 1 + washer (D) x 1 + spring washer (E) x 1 and dometut (F) x 1. (Figure 1)
- 4 - 2. Connect the tie bar (G) to the ladder stabilizer bar by using bolt (B) x 1 + washer (D) x 1 + spring washer (E) x 1 and dometut (F) x 1. (Figure 2)



(Figure 1)

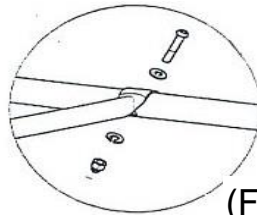

(Figure 2)

- 4 - 3. Fasten the tie bar (K) to the chute bottom suport tube (P) by using bolt (B) x 1 + washer (D) x 1 + spring washer (E) x 1 and dometut (F) x 1. (Figure 3)

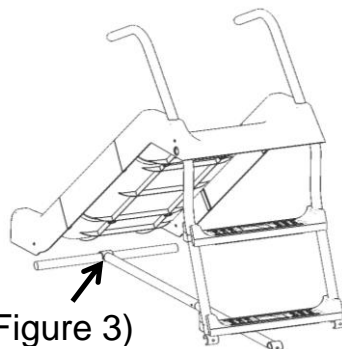

(Figure 3)

- 4 - 4. Fasten the chute bottom suport tube (P) to the both sides of Bottom slide chute (W) together by using bolt (A) x 1. (Figure 4)

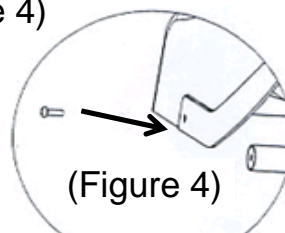

(Figure 4)

- 4 - 5. Fasten both sides of the ladder stabilizer bar (I) by using the ground anchor (O) on the ground.

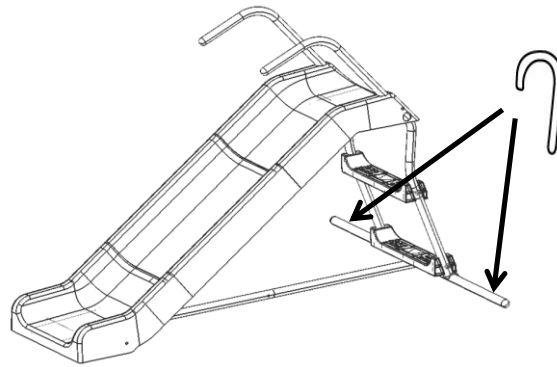

Page 8 of 9

- 4 - 6. When selecting a place to install the equipment, take into account the space required for the training activity. Allowing a margin of at least 40 feet (1 meter) on all sides. For this reason, avoid positioning the equipment near protruding elements, walls, treescape, etc.
- 4 - 7. Once the equipment has been assembled, make sure that it is placed safely and completely stable, never on carpet (it must be perfectly stable, not least under conditions of maximum load).
- 4 - 8. Do not install the equipment inside the sauna or any wet area. Because it may cause rusty.

## Care and Maintenance

1. This equipment must be assembled and checked by an adult.
2. Regularly check all nuts and bolts for tightness before use and replace any worn, defective or missing parts. DO NOT try to repair broken parts.
3. Regularly check that the slide, steel tube and other parts are tightened completely and replace worn & damaged parts when necessary.
4. Remove wore and damage parts and refrain from using the slide until the parts are replaced.
5. At the beginning of each season, oil all metal parts and do so regularly when necessary during use.
6. Place this equipment on a well-lite area.
7. The slide should be kept dry – do not use when parts are wet.
8. This item is not designed for adults. The maximum weight of 1 child is not to exceed 77 lbs (35 kgs).
9. Retain these instructions for future reference.
- 10.Keep this equipment clean and free of debris and dirt.



